

# IMHX<sup>TM</sup> 2019

24 - 27 September  
NEC • Birmingham

The UK's largest  
intralogistics event

Sponsored by



Investec

Corporate & Investment Banking



▶ **PREVIEW**

[www.IMHX.net](http://www.IMHX.net)

# ▶ IT'S SHOW TIME

Editor **Kirsty Adams** reflects ahead of IMHX 2019.



The International Material's Handling Exhibition (IMHX) is never far from our thoughts at SHD, even when it's two and a half years away. We're not just a media partner, we are the organisers, part of the same Informa Markets team that delivers the UK's largest logistics event. We produce the conference, we feature the exhibitors, we invite our Logistics 100 to attend, we hear the highs and lows from the sales team who sit beside us and the queries that the operations team receive.

We are IMHX, and it's threaded through everything we do. I see IMHX as the event that sits at the centre of our SHD solar system, orbited by our monthly magazine, the SHD Logistics Conference, The Logistics Podcast, The Logistics Awards and so on. This is the event where our community comes together. It's a busy, exhausting week where we survive on adrenaline, coffee and the knowledge that we'll hit a record number of steps on our Fitness App of choice.

It's where I get to talk to my readers, facilitate conference sessions and see the latest technology in action. In 2019 I'll be releasing three podcasts whilst at IMHX, so do make sure you have subscribed.

## HIGHLIGHTS

I would argue, that every speaker we've organised in 2019 is a highlight (forgive the brag). We decided to produce Centre Stage theatre content similar to that of the SHD Logistics Conference which is always a sold-out event. Speakers include Caroline

Luxton, head of Logistics at LoveCrafts, who featured on our podcast *The new King of Retail* earlier this year. As a business, LoveCrafts is just eight years old, and has transformed how people buy their wool, cotton and craft materials. Other sessions include a panel with Transport Intelligence (Ti) entitled *Start-ups and Disrupters*.

This session will feature a number of start-ups entering the world of logistics with new platforms and innovative solutions set to change the industry. All sessions on the Centre Stage theatre on Tuesday 24, Thursday 26 and Friday 27 September are free to attend.

On Wednesday 25 September the eagerly awaited Women in Logistics annual conference will take to the Centre Stage Theatre and feature Professor Omera Khan on how to use design to unlock value in the supply chain. Elizabeth Coggins-Hill, a supply chain transformation leader, will discuss modern slavery in the supply chain. As usual the Women in Logistics conference content is top quality. To book your place visit: [ciltuk.org.uk/Events/Annual-Women-in-Logistics-Conference](http://ciltuk.org.uk/Events/Annual-Women-in-Logistics-Conference).

## BREXIT BACKDROP

With the Brexit backdrop so prominent in the lead up to IMHX 2019, we weren't sure how things would turn out. Would it put exhibitors off, all this uncertainty? I'm pleased to say, it has had the opposite effect. The uncertainty has become a call to action for logisticians who are preparing their operations for

whatever Brexit throws at them, and our exhibitors are showing up ready.

Education, technology and collaboration are required for this journey. As I write, over 430 exhibitors have booked, which is the highest number in IMHX's history. We have over 100 hours of content all geared to deliver the best IMHX ever. It's one not to miss, and you can register for free at [www.imhx.net](http://www.imhx.net).

Kirsty Adams  
**Editor**  
SHD Logistics





# Your partner for growth, at every stage of the journey

Our clients share an appetite for growth and the need for the right banking partner to support them on their journey.

That's why we tailor solutions to our clients' needs, taking the time to fully understand their requirements and challenges.

Through agility, speed and exceptional service, we offer deep expertise across a range of services.



Working capital - invoice discounting, asset-based lending and supplier finance



Treasury risk solutions - foreign exchange, interest rates and commodity price hedging



Cash products - a range of call, notice and fixed deposits

Get in touch to find out more

 0207 597 3511

 [NCE@investec.co.uk](mailto:NCE@investec.co.uk)

 [investec.com](http://investec.com)



Solutions. Capital. Empowered people.



# ▶ EVENT OF 2019

With a vast array of equipment, services and cutting-edge solutions on show, **IMHX 2019** is this year's essential intralogistics event.

**IMHX 2019** is set to be the biggest and most successful event in the long running IMHX series of materials handling exhibitions to date.

Over 400 exhibitors – including Dematic, Swisslog, Knapp, Vanderlande, Toyota, Crown, Doosan, Briggs and Hyster-Yale – will deliver live and dynamic demonstrations of the latest technological developments that are shaping the modern logistics industry.

IMHX 2019 exhibition director, Rob Fisher, comments: "IMHX is always a key diary date for logistics professionals. With the vast array of equipment, solutions and technology on show this year, IMHX 2019 is no exception. "Supply chain issues are at the top of every company's agenda," he continues. "The relentless rise of e-commerce is forcing retailers, manufacturers and logistics operators to adapt the design of their facilities to keep pace with today's consumers who demand ever-faster and more efficient delivery of goods. "As a result, traditional storage warehouses are being transformed into massive technology-enabled, high-volume order-fulfilment centres to ensure every square inch of the site is optimised."

Developments in intralogistics systems are advancing more rapidly than ever before and many of the changes are, not surprisingly, being driven by developments in automation and robotics.



## AI & AUTOMATION

This ever-expanding role of AI, automation and robotics within the modern supply chain will be reflected at IMHX 2019.

"With over a third of exhibitors showcasing some form of automation, robotics, autonomous vehicles or new tech, visitors to IMHX will be able to see and feel this cutting-edge technology for themselves. What's more is the opportunity to get a greater understanding of how it can be implemented and deliver the operational benefits they are looking for," says Fisher.

In addition to hundreds of product launches and demonstrations, the IMHX Technology Arena – new for IMHX 2019 – is likely to be of particular interest to visitors. This exciting new zone, which is being delivered by the Automated

Material Handling Systems Association (AMHSA) – the leading trade association for logistics automation providers – will allow visitors to experience the evolution of picking technology that is enabling the rise of e-commerce.

AMHSA secretary, Dave Berridge, comments: "AMHSA will be provide an interactive feature that explains picking technological developments and demonstrates how automation brings speed and accuracy to the picking operation. AMHSA experts will be on hand to explain different picking technologies and provide professional advice on all aspects of logistics automation."

One of the show's many trade pavilions will be hosted by the United Kingdom Warehousing Association (UKWA) and will showcase the best third-party logistics (3PL) companies.

## ▶ FORKLIFT OPERATOR CHALLENGE

The UK's top fork lift truck drivers will put their skills to the test in a live Forklift Operator Challenge, taking place throughout IMHX 2019.

Organised by Talent in Logistics in partnership with UniCarriers, the Forklift Operator Challenge will see lift truck operators undertake a series of tests designed to show their skills, knowledge and understanding of the need for safe forklift operation.

Ruth Edwards, business manager at Talent in Logistics, says: "Forklift operators don't tend to get highly recognised for their hard work, which

is why we want to celebrate these individuals and encourage them to continue their efforts.

"The Forklift Operator Challenge will also demonstrate the importance of skilled, safe and efficient forklift operators to the productivity and profitability of any company."

Chris Bates, sales director at UniCarriers UK, comments: "The operators taking part will use the award-winning Unicarriers TX3 electric counterbalance truck and UniCarriers will provide each entrant with a truck familiarisation session before they compete to ensure that they enjoy the truck's

new technology and extra features."

Any qualified counterbalance lift truck operator can register to take part in the Forklift Operator Challenge by visiting stand 6B190 at any time during IMHX 2019 or by contacting Talent in Logistics in advance by email at [talentinlogistics@capitb.co.uk](mailto:talentinlogistics@capitb.co.uk).

Rob Fisher, IMHX 2019 event director, comments: "Transport, logistics and the supply chain need ever-increasing and changing skills to keep Britain moving and the Forklift Operator Challenge is just one of a number features planned that will highlight the importance of skills and training at IMHX 2019."





**UKWA PAVILION**

UKWA CEO, Peter Ward, says: "The UKWA Pavilion is going to generate a lot of interest among visitors. The increasing need for flexible and agile supply chains means that more and more companies are turning to third party providers and realising the benefits of sub-contracting supply chain activities to experts."

Fisher adds: "UKWA is a dynamic and vibrant trade association whose members include some of the most significant companies in the UK logistics industry. Third-party logistics is growing at a significant rate and the UKWA Pavilion will be the place where visitors can meet some of the leading companies in the sector."

Meanwhile, the skills gap remains high on the agenda at IMHX 2019. The Skills Zone will provide an opportunity for young people to participate in a range of interactive features that demonstrate the diverse career options that logistics offers. It is being delivered in partnership with The Big Bang Near Me – organiser of a programme of UK-wide events designed to encourage students to become interested in science, technology and engineering, and Think Logistics – a sector-led initiative that aims to redefine the image of working in logistics.

In addition, the Skills Zone is being supported by several key industry bodies, including the Chartered Institute of Logistics and Transport (CILT), NOVUS and the British Industrial Truck Association (BITA).



# FREE-TO-ATTEND SEMINARS

An inspiring line up of speakers will address the critical developments driving change across the supply chain sector during a series of free-to-attend seminars taking place across four days at IMHX 2019. The line-up include Alex Harvey, general manager OSP Warehouse Automation, Ocado Technology; David Hix, Supply Chain director, Nestle UK&I; and Steve Hawthorn, Distribution Centre general manager, Jack Wills.

"The spotlight will fall on the technologies transforming logistics – including AI, robotics and automation and cover many of the themes affecting supply chain professionals today," says conference producer, David Tran.

"With over 100 expert speakers and facilitators giving fresh insights into the ways supply chain strategies are shifting and changing focus, the seminar programme will deliver relevant content that ensures logistics professionals make the most of their time at IMHX 2019," he adds.

As well as a Keynote Arena and The Big Bang @ IMHX Skills Zone, visitors can attend informative sessions within the Technology Solutions Forum where they can learn how new cost-saving logistics technology is being implemented within operations from real life case studies.

Leading industry bodies and associations such as Women in Logistics (WiL) and the United Kingdom Warehousing Association (UKWA) will also be holding conferences between 25–26 September at IMHX 2019.

**Find out more about the conference programme on pages 38, 39 & 40**



**BRIDGING THE GAP**

Bethany Fovargue, operations manager at NOVUS, says: "The logistics sector employs a total of 2.35 million people in the UK, either directly or indirectly. That's a huge number, accounting for nearly 8% of the UK workforce. With demand on the logistics sector forecast to grow significantly in the coming years, employers need to have the best talent on board. That is proving quite a challenge.

"Transport, logistics and the supply chain need ever-increasing and changing skills to keep Britain moving. The IMHX 2019 Skills Zone will bridge the gap between young people looking for a rewarding career and logistics companies seeking talented individuals capable of moving the profession forward."

Visitors and exhibitors alike will also have access to four days of exciting educational content, completely free of charge. The conference programme at IMHX 2019 will feature a roster of inspiring thought leaders from leading organisations who are changing the face of logistics (see p38-39). The seminar programme will also offer practical knowledge, strategic insights driven by real-life case studies, and further essential professional career development.



## ▶ MEET SOMEONE NEW AT IMHX 2019

Among the 400+ intralogistics solutions providers exhibiting at IMHX 2019, there will be a significant number of companies exhibiting for the first time, bringing with them never-before-seen innovations in supply chain technology.

Exhibitors making their IMHX debut at this year's event include many robotics specialists, loading bay experts, fork lift truck suppliers and automated handling solutions providers.

This exciting list includes:

- Forklift manufacturer **BYD** which will unveil a new generation of lithium-ion powered lift trucks that offer multi-shift performance without battery changes;
- **Campisa** will highlight its range of low maintenance and highly cost-efficient loading bay doors and dock levellers;
- Swiss materials handling specialist **WRH Global** will premiere a mobile sortation system that has been designed to be ideal for e-commerce companies;
- **SITMA** will present an innovative product packaging solution for e-logistics;
- Swiss-Swedish giant, **ABB**, will have a strong presence and will demonstrate examples from its extensive range of robotics and automation technology;
- **JCB** will highlight the JCB 30-19E – the first electric-powered model in its multi-award winning Teletruk telescopic lift truck range;
- **6 River Systems** will show its flexible and scalable warehouse automation solutions that are powered by collaborative robots and artificial intelligence;
- **RAX** will exhibit its range of highly innovative automation solutions for picking small items with wide SKU ranges;
- **Geek+** will highlight a collection of intelligent robot-based logistics solutions.

Fisher, says: "The high number of first-time exhibitors reflects the increasing emphasis placed on logistics and supply chains within the modern business environment.

"Of course, visitors to IMHX will meet some of the biggest and best-known global suppliers of intralogistics solutions, but they will also be able to see some of the interesting developments that are being offered by a host of companies with which they may be less familiar."





# MAX/AGV

## Benefits of an AGV System

- Cost effective
- Flexible
- Safe
- Expansion and Changes
- 24 Hours service
- Careful Handling
- System Integration
- Accessible Layout
- Load Scheduling & Priorities
- High Availability



Standard AGVs & special designs. Adaptable software & hardware. To suit your needs.

Website [www.maxagv.com](http://www.maxagv.com)  
Phone number +46 31 340 13 50  
Mail address [info@maxagv.com](mailto:info@maxagv.com)

## Craemer Plastic Pallets

Your reliable, adaptable and cost effective alternative to wooden pallets

### The CB Pallet Boxes



- Manufactured in one piece from food-grade HDPE
- Available as CB1 (1200 x 800 mm) and CB3 (1200 x 1000mm)
- Weight: 34.5 kg (CB1) / 36.5 kg (CB3)
- Volume: 470L (CB1) / 610L (CB3)
- Available in a range of colours
- Personalisation and RFID options available

For more details contact our sales team on:

**0800 032 4291**

[enquiries.uk@craemer.com](mailto:enquiries.uk@craemer.com)  
[www.craemer.co.uk](http://www.craemer.co.uk)

Visit us on stand 18M20 at IMHX  
24<sup>th</sup> - 27<sup>th</sup> September 2019, NEC

  
**CRAEMER**  
Quality, the best value.

**IMHX 2019**  
The UK's largest intralogistics event  
24 - 27 September | NEC - Birmingham

Visit us!  
Hall 20, Stand 19J40



## Innovation and intelligence for the future of intralogistics

Interroll launches a new DC platform: RollerDrive EC5000, MultiControl and Power Supply.

- 24V or 48V versions available.
- Wide power range for different applications: 20W, 35W or 50W.
- Extremely precise positioning thanks to an advanced CANopen bus interface.
- RollerDrive EC5000 tube diameter of 50mm or 60mm.
- Predictive maintenance thanks to feedback providing information on the lifetime status of the RollerDrive.

[interroll.co.uk](http://interroll.co.uk)

Interroll Limited  
Phone: +44 15 36 31 27 70  
Mail: [gb.sales@interroll.com](mailto:gb.sales@interroll.com)



INSPIRED BY EFFICIENCY





**REGISTER NOW**

Registration is now open to attend IMHX 2019 on 24–27 September 2019. Visitors are encouraged to pre-register. To secure your free visitor pass that allows access to all areas of the show on any of the opening dates, visit the IMHX website.

Executives from many of the biggest names in retailing – including Tesco, Marks & Spencer, Aldi, Ocado, ASOS, Next, Sainsbury’s, John Lewis, Morrisons, Nisa and Lidl – have already registered to visit the show.

Fisher comments: “IMHX represents an outstanding opportunity to see and experience the cutting-edge technology that is driving supply chain efficiency and get a greater understanding of how it can deliver the operational benefits retailers are looking for.

He continues: “The changing face of retailing is forcing companies in the sector to adapt the design of their storage and distribution centre facilities to keep pace with the demands of today’s consumer. The most successful retailers realise that adapting and evolving the supply chain gives a competitive advantage and, for executives tasked with identifying ‘better’ solutions, a visit to IMHX 2019 is essential.”

“When planning either a new-build storage facility or upgrading an existing site, careful thought is required from the outset to ensure that the best possible solution is specified and it’s important to properly evaluate all the options open to you at an early stage: that means talking to as many equipment suppliers as possible.

“A visit to IMHX is a great chance to see hundreds of state-of-the-art intralogistics solutions under one roof and a wonderful opportunity to get a greater understanding of how modern technology can deliver the operational benefits you are looking for,” ends Fisher. ■

**▶ NAGA MUNCHETTY TO HOST THE LOGISTICS AWARDS**

Popular television presenter and journalist, Naga Munchetty, will announce the winners of this year’s Logistics Awards at a gala evening taking place on Thursday 26 September during IMHX 2019. Over 600 senior professionals from leading retailers, manufacturers and

logistics operations are expected to attend The Logistics Awards dinner, which will be held at the VOX Conference Centre, Resorts World at the NEC Birmingham.

The Logistics Awards 2019 will feature 13 award categories including the Environmental Award, Technology Transformation Award and – new for

2019 – a Wellbeing Initiative prize.

“The Logistics Awards recognise intralogistics and supply chain excellence and will be an important part of IMHX,” concludes Fisher.

**To find out more about the networking night of the year see pages 68 to 72**







**IMHX<sup>TM</sup>**  
**2019**

24 - 27 September  
NEC • Birmingham

The UK's largest  
logistics event

Visit EnerSys on Stand 20D148

AD Group Ltd

# Zero battery change



## We give you **nrg.**

NexSys<sup>®</sup> is the TPPL battery for industrial vehicles designed by EnerSys<sup>®</sup> to ensure maximum power with optimum performance and low TCO. Faster recharging cycle with opportunity charging whenever you want, a fully operational fleet even with partial states of charge, Zero Battery Change and virtually no maintenance with a longer cycle life. NexSys is ready, flexible power that will never let you down.

[www.discovernexsys.com](http://www.discovernexsys.com)

**EnerSys Ltd** Oak Court - Clifton Business Park - Wynne Avenue - Swinton - Manchester M278FF - Ph. 0161 79 4611 - [quotes@uk.enersys.com](mailto:quotes@uk.enersys.com)

Sponsored by



Corporate & Investment Banking

# Why visit IMHX 2019



**PRODUCT LAUNCHES AND LIVE DEMOS OF WAREHOUSE AUTOMATION,  
AI, ROBOTICS, FORKLIFTS, PICKING SYSTEMS AND MANY MORE**



REGISTER NOW FOR FREE  
[www.imhx.net/attend](http://www.imhx.net/attend)

# IMHX<sup>TM</sup> 2019

The UK's largest intralogistics event  
24 - 27 September | NEC • Birmingham

- **Four action-packed days** of product launches, live demonstrations, keynote speakers and networking events
- Meet **16,000+ senior professionals** from all areas of the logistics and supply chain industries
- Connect with **400+ suppliers** exhibiting intralogistics solutions
- Improve your network strategy with **100+ hours** of **free-to-attend** presentations, seminars and workshops
- Experience **dynamic feature areas** including the Forklift Truck Demonstration Zone, Technology Arena, Logistics Solutions Forum and the Future Skills Zone
- Gain critical supply chain insight from **80+ expert speakers**
- Visit **trade pavilions** hosted by **leading industry associations** including UKWA and AMHSA



REGISTER FOR YOUR FREE TICKET AT [WWW.IMHX.NET/ATTEND](http://WWW.IMHX.NET/ATTEND)

# CENTRE STAGE

The speaker line-up for the IMHX Centre Stage theatre includes leading logisticians from **Ocado**, **Coca-Cola** and **Leidos**. The three-day conference agenda focuses on topics across retail, automotive, property and third-party logistics.

The Centre Stage conference is free to attend on Tuesday 24, Thursday 26 and Friday 27 of September. On Wednesday 25 September The Centre Stage theatre is reserved for the **Women in Logistics** Conference (see p40 for more information on how to book your place).

## FEATURED SPEAKERS

**DAMIAN  
ALEXANDER**  
VP AND MANAGING  
DIRECTOR – LOGISTICS  
LEIDOS



**Session: Transforming MOD logistics through technology, people and process**

For commanders of the UK Armed Forces, agile supply chain management is critical to every operation, from hurricane relief and humanitarian aid to new deployments and training programmes at military bases around the globe. The supply chain demands of the military today are not unlike the demands on enterprise. And with help from Leidos, the UK Armed Forces is able to leverage best-in-class technology solutions that rival those deployed by private sector leaders like Amazon, FedEx and WalMart. Hear from Damian Alexander CBE on how the Ministry of Defence is getting troops what they need, when they need it and at lower cost.

**CLARE BOTTLE**  
ASSOCIATE DIRECTOR,  
WAREHOUSING  
COCA-COLA EUROPEAN  
PARTNERS



**Session: "This Is Forward" – The logistics of being more sustainable**

As a total beverage company, Coca-Cola European Partners (CCEP) has bold ambitions, set out in "This Is Forward", the company's sustainability action plan. But if we're committing not to send anything to landfill, how will we manage the logistics of surplus stock? Clare will talk about CCEP's partnerships and policies and bring to life the challenge to reduce, reuse and recycle on a global scale.

**PHILIP SHAW**  
CHIEF ECONOMIST  
INVESTEC

**Session: Is this the Brexit endgame?**

The UK's extended Brexit deadline is looming, while a new Prime Minister has been appointed. But are we facing the same old issues, just with different packaging? Can the government get a deal through parliament at the same time as getting an agreement with the EU? Or are we looking at another delay to the UK's exit? And what of the prospects of leaving the EU without a deal? Investec's chief economist Philip Shaw looks at these issues and how the economy is likely to respond to these and other challenges.

## KEYNOTE SPEAKER



**TESSA  
ENGLISH**  
DIRECTOR - UK  
RESEARCH  
JLL



**Session: The future of London's industrial and logistics market – what's on the horizon?**

Tessa will talk you through the challenges and opportunities currently facing London's industrial market. With a large amount of industrial land already lost in London to other uses, and an increasing need to service a growing city which is coupled with the need to tackle pollution and air quality issues in London, this has led to the need for industrial intensification. The session will look at the opportunities that are coming forward in London to help create new industrial space in the city that operators can use to undertake their last mile fulfilment, and also touches on other large cities across the globe where this is already happening.

**ALEX HARVEY**  
GENERAL MANAGER  
FOR WAREHOUSE  
AUTOMATION AND  
EMBEDDED SYSTEMS  
OCADO TECHNOLOGY



**Session: The Intersection of digital Twins, AI and Robotics for Logistics**

Artificial intelligence and robotics can have transformational impact in allowing logistics providers to unlock new market potential. To fully maximise the business impact of these technologies, at Ocado we build high-fidelity digital twins of our warehouses and other parts of our business. These digital twins enable us to evaluate new algorithms, test production software before we deploy it, optimise our systems and even generate data to train ML models before the real data exists. This talk will explore how the combination of AI, Robotics and Digital Twins can be used to generate operational efficiencies, as well as offer a route to improvements and innovations of the underlying logistics proposition.



**STEVE  
HAWTHORN**  
DISTRIBUTION CENTRE  
GENERAL MANAGER  
JACK WILLS



**Session: When two become one: the logistical headache**

Jack Wills was challenged by some major changes taking place at its Sheffield multichannel distribution centre. Faced with the outsourced distribution company pulling out of the contract, strong leadership and effective operations management were crucial to re-organise warehouse operations. The emphasis that the leadership placed on maintaining the Jack Wills values of employee engagement and empowerment resulted in innovative approaches, and operation goals being surpassed. Jack Wills Distribution Centre general manager Steve Hawthorn will share his experience of the company's journey into the unknown of managing its own logistics operations.

**PROFESSOR  
JOHN  
MANNERS-  
BELL**

CEO  
TRANSPORT  
INTELLIGENCE



**Session: Ti Innovation: Start-ups and Disrupters (Panel)**

This session, headed up by Ti, CEO, John Manners-Bell and Technology Expert and Ti Advisory Board Member, Ken Lyon, will feature a number of start-ups entering the world of logistics with new platforms and innovative solutions set to change the industry. John and Ken, with their long-standing experience, will ask challenging questions to dig deep into what sets each company apart and why they believe they will succeed.

**AMY  
SHORTMAN**  
CEO  
ASC ASSOCIATES



**Session: CAR-T personalised medicines: how a pharmaceutical company is utilising data for compliance and operating ability**

With healthcare products becoming more complex in nature, there is a need for the logistics industry to ensure that temperature, humidity, visibility and security across its supply chain are compliant. Whilst we are on the curve of technological advancement within the supply chain, many are fragmented and disjointed. This session looks at how manufacturers have used data and technology to enhance shipping practices and improve overall quality of the product.

**PAUL WHYTE**  
BUSINESS UNIT  
DIRECTOR (SHARED  
USER)  
BEST FOOD LOGISTICS

**Session: Using simple technology and Big data to transform profitability**

Paul is a managing director at Best Food Logistics and was appointed by the parent company to run a turnaround in June 2017. In this session Paul discusses what has transpired in those two years, during a period in which he had assembled and led a team that has transformed what was a heavily loss-making business known as Bidvest Logistics, into an instantly recognisable, service led and profitable brand. Operating in a poor service industry, Best Food Logistics has successfully differentiated itself through simple technology that utilises Big Data to lock in and continually demonstrate exceptional service levels and value to its customers.

▶ **THOUGHT LEADERSHIP**



IMHX 2019 will have over 80 expert speakers, and over 100 hours of free-to-attend presentations, seminars and workshops.

Go to [www.imhx.net](http://www.imhx.net) to see the line-up across the four speaker theatres across the show, including the Centre Stage.

# ▶ UNLOCK VALUE



We interview **Professor Omera Khan** about supply chain design ahead of her talk at IMHX 2019.

**Kirsty Adams (KA):** Prof. Khan, at the upcoming Women in Logistics Conference which takes place at IMHX on Wednesday 25 September 2019, you'll be speaking about using design to unlock value in the supply chain. Can you tell us why this is an important topic in 2019?

**Omera Khan (OK):** *It's estimated that up to 80% of a product's eventual supply chain costs are already present at the early phases of design and development. Hence, decisions taken at the design stage of a product's lifecycle affect that product's subsequent value to a business. However, the often disconnect or misalignment of functions across the design to delivery process means that decisions taken on the drawing board do not consider the costs of transportation, or the risks at sourcing location or distribution channels, or the complexity involved in manufacturing the products that impacts the responsiveness to deliver.*

*The 'new' normal operating environment is unpredictable and volatile, requiring businesses to be smarter, flexible and more responsive. In 2019 particularly we have seen heightened media attention to sustainability issues, sparked by the devastation caused by plastic waste and general level of waste produced globally, the impact of climate change, and resource issues due to increase in consumption, travel and meeting the needs of a massively growing population has forced us to rethink about our sourcing and manufacturing options and consider reshoring or near sourcing, hence, designing closed-loop supply chains further adds to the growing list of expectations by firms to improve supply chain management and 'design for sustainability' is increasingly realised as being essential to long-term corporate planning.*

*We are already seeing companies, for example, in the UK textiles sector considering how to source and manufacture 'back at home'. Whilst from a sustainability perspective this could be seen as a quick win, it raises questions for the global shipping and logistics industries, where trade may*

*no longer be about only shifting finished products from point A to B but rather more logistics may need to think about new value adds that they provide for example, in security risk management and assembly.*

*Whatever that may be the point is that supply chains are no longer about only serving end customers, supply chains must also be about preserving the planet and the environment.*

**KA:** What's around the corner for supply chains?

**OK:** *Transforming our supply chains to perform effectively in a very different world, where the prospects of more border checks as nationalism and protectionism take rise. Where Ai, robotics, augmented reality, additive manufacturing and machine intelligence replace our more traditional methods and business approaches requiring us to unlearn and relearn new tools. Where demand has shifted from being so time sensitive to being environment sensitive, thereby consumption may indeed slow down or vanish, which would have massive implications to global supply chains. Design for supply chain management will clearly increase in significance as the need to understand our product and its resource implications as well as its usage, footprint and disposability or depletion now become more important than fast fashion, for example, and how many times we can buy, consume and waste new products. Fast fashion will be replaced by sustainable fashion.*

*I advise companies to start scenario planning for their businesses to mitigate the impacts of disruptive innovation that have the potential to wipe them out if they do not adapt to the new landscape around the corner. Scenario planning could be a useful risk management tool as it alerts businesses to the potential uncertainties and unknowns and for plan for these. ■*

## ▶ WIL AT IMHX 2019

The Women in Logistics Conference takes place at IMHX on Wednesday 25 September. To book your place visit [ciltuk.org.uk/Events/Annual-Women-in-Logistics-Conference](http://ciltuk.org.uk/Events/Annual-Women-in-Logistics-Conference).

Speakers include:

- Professor Omera Khan (Risk Intelligence, Royal Holloway University of London) - Using design to unlock value in the supply chain
- Elizabeth Coggins-Hill (Supply Chain Future)- What can we do about modern slavery in the supply chain?
- Chris Green (Young Foodies) - How a level playing field drives growth and innovation in small brands
- Martin Port (BigChange) - A technology entrepreneur's view of the logistics sector.
- Caroline Barber/Florence Bearman (Transaid) - Innovating to reach the last mile and reduce child mortality from severe malaria: a case study from Serenje District in Zambia
- Jennifer Swain (Clipper Logistics) - Diversity and Inclusion
- James Gill (CEVA Logistics) - Rebooting finance



# BIG BANG AT IMHX

IMHX CONFERENCE PROGRAMME

In 2019 the 'Big Bang at IMHX' zone features talks on how to attract staff, create a talent pipeline and retain the rising stars.



## ANDY KAYE

CEO, BIS HENDERSON GROUP

### The Apprenticeship Levy: Making it work for your business

Getting to grips with the complexities and potential benefits of the Levy can be overwhelming. Andy's presentation aims to provide delegates with an understanding of how the Levy affects your business and how to use it to the greatest effect.



## IAN NICHOL

HEAD OF LOGISTICS, CAREER READY AND STEVE GRANITE, CEO, ABBEY LOGISTICS

### Opening up logistics to young people and securing future talent

Young people, teachers and parents predominantly see logistics as 'just trucks and sheds', rather than an essential, dynamic, exciting sector that can offer great careers. So, how do we address this disconnect and secure the future talent we need? Our speakers share how they are proactively engaging with schools and colleges to encourage young people to 'Think Logistics'.



## ANDY PAGE

FOUNDER, BUSINESS ON THE MOVE

### "Staff wanted for invisible jobs; apply by accident"

Andy's session will discuss his views on the mystery that is recruitment into the logistics and supply chain sector, his concerns around the invisibility of an industry that is so vital to the economy and the opportunities the sector offers the people that do accidentally fall into it.



## LOUISE CURD

DIRECTOR OF PROGRAMMES, LEARN BY DESIGN

### Making an impact through schools engagement: Our future workforce

An in-depth look at opportunities and ways to engage the future logistics workforce about exciting career opportunities in the sector.



## RUTH EDWARDS

BUSINESS MANAGER, TALENT IN LOGISTICS

### How organisations can attract and retain talent through employee engagement

It's all very well and good recruiting young people into our amazing profession, but how do we retain them once they are with us? Ruth will be talking all things employee engagement, using insights from a recent research study by Talent in Logistics. She will highlight what young people think is important from their employer, covering topics such as internal comms, leadership and corporate social responsibility.



## CARL HOBBS

BIFA, AND ADAM WILLIAMS, MALTACOURT

### How to attract, retain and develop early talent

Recruiting, retaining and developing early talent is not always that easy. In this session, Carl and Adam will give some very simple, practical tips that will work for companies of all sizes. They will also talk about the benefits of supporting new-to-industry talent, its importance, and how organisations will benefit from this approach by being able to engrain a buoyant and successful culture and train new staff without any industry preconceptions.



## EMILY CLARK

APPRENTICE CIVIL ENGINEER, PD PORTS

### From placement to apprenticeship and beyond

Emily joined PD Ports as an apprentice civil engineer in 2018, following a successful four-week internship, which she had secured through the Tees Valley Logistics Academy. Having gained an insight into logistics as a result of her work with the Academy, she quickly turned her focus from architecture to a career in engineering.



## TIENNE OATES

LOGISTICS PROJECT MANAGER, WINCANTON

### How to fall into logistics...

Tienne's journey went from trying to decide between Geography and Business Studies at 18, to being named a Rising Star in the SHD "Logistics 100" at 23. It's strange how things fall into place! Tienne is at IMHX to share her experience with visitors to the conference.

▶ CONTINUES ON P44

**▶ AGANTO**  
**LOCATED: HALL 19,  
 STAND H128**

This year will be the company's third time exhibiting at the tri-ennial event. On the Aganto stand 19H128 there will be an augmented reality demo and a 360° virtual reality experience. Aganto's marketing manager, Hazel Lowe explains: "We are making use of new technologies

like AR to enhance the buying process. It's not always easy to visualise buildings in situ, so AR is really quick and useful tool for achieving this. Aside from digital though...the real focus for Aganto at this year's show will be on stockpiling and helping businesses manage growth.

"The challenges around Brexit and economic uncertainty were topical for IMHX in 2016, a few months after the vote to leave the EU. Now in 2019, with the 'Halloween' Brexit deadline just around the corner, the necessity to be flexible on costs and space is even greater. I'm sure a lot of visitors to the event will be acutely aware how the expense of off-site storage has reached new heights recently, so our practical solutions offer a great opportunity for warehousing and logistics professionals to mitigate this risk," she continues.

In addition to the on-stand AR/VR demos, Aganto is offering free planning for enquiries and orders placed at the show. Visitors to the stand will also be able to try their luck in guessing the number of piggy-banks and pick up branded goodies. ■



**AGANTO**  
 TEMPORARY BUILDING SPECIALISTS

**VISIT US AT STAND 19H128**  
 FOR THE PERFECT  
 INDUSTRIAL  
 BUILDING SOLUTION

**IMHX<sup>TM</sup> 2019**  
 The UK's largest intralogistics event  
 24 - 27 September | NEC • Birmingham  
**SAVE THE DATE**

FAST, FLEXIBLE INDUSTRIAL BUILDING SOLUTIONS

01635 202979
 [www.aganto.co.uk](http://www.aganto.co.uk)



# ▶ B+ EQUIPMENT

LOCATED: HALL 20, STAND D140

B+ Equipment is an automation branch of the Sealed Air group. B+ Equipment manufactures high speed packaging solutions specifically for the order fulfillment industry, either B2B distribution or e-Commerce.

The B+ portfolio consists of several solutions to erect and seal corrugated boxes, where B+'s signature is the reduction of erected boxes to the exact height of the products inside without cutting the corrugated material. B+ offers a unique expertise to standardise box sizes without increasing the cost of corrugated versus a manual packing process.

At IMHX B+ will exhibit the I-Pack solution live and explain why and how it is perfectly suitable to single and multi-order profiles and it can be interfaced to all picking systems including those based on direct picking in the shipping container.

B+ will also exhibit the Priority Pack solution live, a solution that suits well to e-Commerce and flat products such as books. The Priority Pack package is made of two

layers of rigid board at encase the products while protecting perfectly the edges.

Sealed Air is the company that invented bubble wrap 60 years ago and keeps on innovating and leading the market of product protection solution. It offers today a unique portfolio of inflatable, foam, and paper materials and solutions with a permanent concern about sustainability. ■

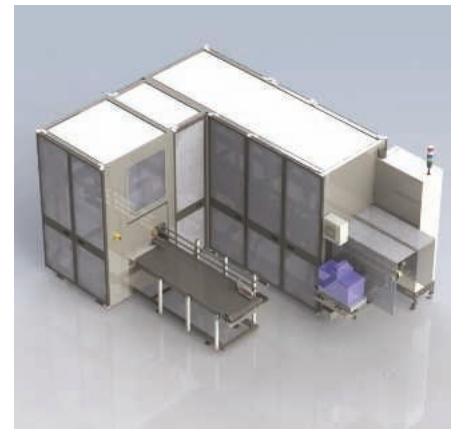

## Packaging automation for order fulfillment

Suitable for B2B distribution and e-Commerce  
Compatible with all picking processes

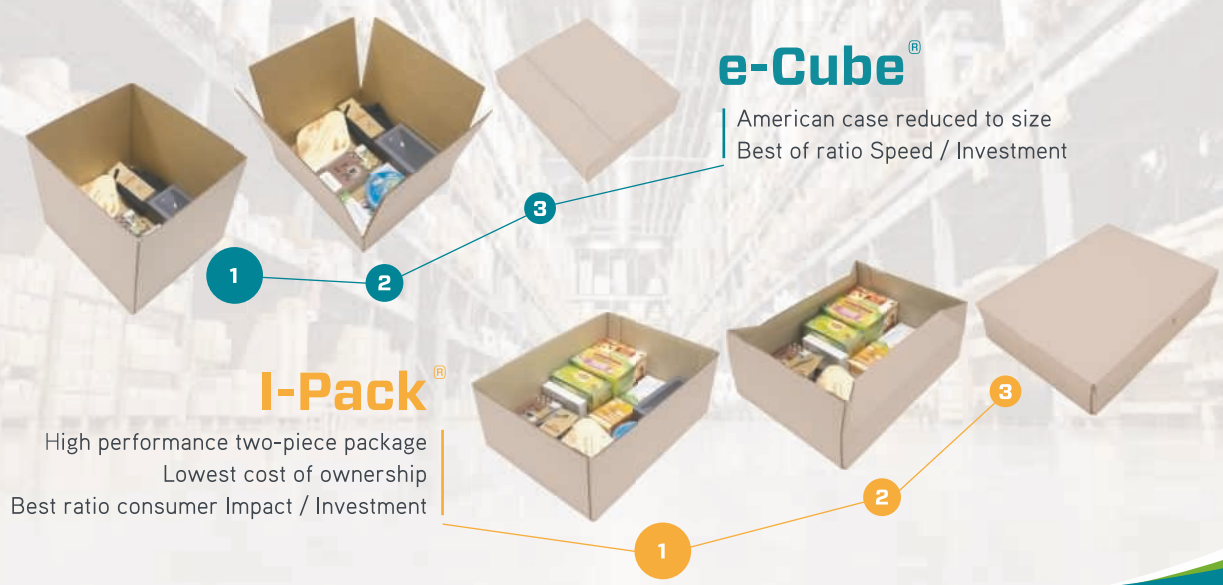

## HARRY UNDERWOOD OUTBOUND DISPATCH, DASCHER

### Harry's journey

Harry joined Dachser in September 2015 and did a two-year apprenticeship. He completed his apprenticeship in August 2017 and began a full-time role at Dachser in September 2017, following on from his apprenticeship. He has been working in the outbound team for over a year and a half now, dealing with both European and national logistics.



## EMMA ROSS WAREHOUSE MANAGER GB + IE, HILTI

### Moving boxes

Having worked across many industries within our profession, Emma will look at the world of logistics from the warehousing and supply chain viewpoint. Using her career to paint the picture of the challenges to the profession, Emma will be looking at the concept of moving boxes and discuss: if that is 'all logistics really is', then why is it so complicated?



**TEACHER PACK**  
Delivering Promises...  
How to solve the returns problem in logistics?

## BETHANY FOVARGUE OPERATIONS MANAGER, NOVUS

### So, you think you know young professionals?

By 2020, 50% of the global workforce will be so-called millennials; with 'attracting millennials to the workplace' yielding over 350,000 results on Google, where do you start in knowing what attracts and retains this demographic? Bethany shares her perspectives on the ways in which a company's culture, management style and approach to retention affects young professional's recruitment choices today.



## ▶ THE TRANSIT-BOLT CHALLENGE

AO.com's logistics head office have teamed up with their local University Technical College in Crewe to help them resolve an ongoing returns issue.

The online electricals store has its own in-house returns function, where pristine products can be returned to stock or re-packed for selling onwards and only slightly damaged items sold at a discount price.

One of the challenges they face is getting brand new (but opened) and unused items back to their Cheshire-based NDC in pristine condition and ready for re-sale. This is where the idea for the challenge has come from.

In March 2019 AO Logistics challenged three groups of year 12 students at Crewe Engineering and Design UTC to come up with a way of reducing or eliminating the damage caused by returning unused-unboxed and nearly new washing machines from all over the UK, back to their NDC in Cheshire. These washers tend to have their transit bolts missing, and the weight of the machine and drum moving around in the back of our vans can often damage the components inside and render them unsuitable for re-sale.

They call it... "The Transit-Bolt Challenge."

Mentored by members of AO's quality, installations, returns and senior operations team the students were fully committed to overcoming this challenge!

**What happened next blew the operational leaders away... find out more during IMHX2019**

### Learn about...

- How a millennial's career journey differs from their predecessors
- Key success factors for a great placement or graduate opportunity
- Tangible efforts to support attraction and retention of millennials



## ▶ OTHER SESSIONS INCLUDE

**Sally Gilson, head of skills, FTA**  
*Future recruitment: How to engage Generation Z*

**Darren Smith, technical trainer & Tom Ainsworths, Apprentice, Dematic**  
*Dematic's apprenticeship journey*

**Karl Baum, managing director, F-TEC**  
*Shaking up the fork lift sector*





# POWERING your BUSINESS



**XTREME FORCE HIGH CAPACITY LEAD ACID BATTERIES TO BE LAUNCHED AT IMHX2019**

*Xtreme Force*  
More Power Under Any Condition >>>

**IBCS**  
INDUSTRIAL BATTERY & CHARGER SERVICES LTD

The **Intelligent Choice**  
TO KEEP YOUR BUSINESS MOVING  
0845 208 8748 | [www.ibcs.co.uk](http://www.ibcs.co.uk)

NEW LITHIUM

SEE US AT

**IMHX<sup>TM</sup>2019**  
The UK's largest intralogistics event  
24 - 27 September | NEC • Birmingham

## Li.ONFORCE PRODUCT SUNLIGHT

- For over 35 years IBCS has been the chosen company to deliver intelligent product and service solutions to their 'blue-chip' customer base nationwide.
- A new IBCS Lithium Ion Battery range has been launched.
- The Sunlight Li.ONFORCE batteries and charger products have been developed and constructed for safe, reliable use in electric fork lift and pallet trucks.
- The battery systems are exclusively designed with high performance Lithium-Ion cells which fulfil all requirements for heavy duty industrial motive power use.
- Choosing the right option for the customer is critical. IBCS offers unbiased expertise on the most effective solution.
- The lithium-ion battery cells and modules have intelligent monitoring and control systems and extensive safety features. A high-frequency opportunity fast charger communicates with the battery via CAN bus protocol.
- The battery system has active protection components which monitor the entire system and prevents any misuse.
- It follows the successful launch of Hydro Save & Motion Gel into the market.
- A wide range of industries depend on and trust IBCS to provide tailor made packages to meet their individual needs.

ferag...  
wrh global...  
UK

New innovation at IMHX:

# denisort compact

Mobile vertical sorter as a compact and modular system

**IMHX<sup>TM</sup>2019**  
The UK's largest logistics event  
24 - 27 September | NEC • Birmingham  
Stand 19J105

[www.ferag-intralogistics.com](http://www.ferag-intralogistics.com) | [www.wrh-global-uk.com](http://www.wrh-global-uk.com)

## ▶ BOTT

**LOCATED: HALL 20, STAND C66**

Bott are world-leading manufacturers and suppliers of workplace storage equipment, with over 80 years of industry experience.



The company has invested heavily in its UK manufacturing plant, allowing it to offer a comprehensive range combined with short lead times. As well as producing and assembling the products, Bott designs and tests them in-house, meaning that when you buy a drawer cabinet with a 200kg per-drawer load rating or a 1000kg rated bench, you can be sure that it really delivers on the job for the long term. In a world of increasing environmental impact concerns, making functional, serviceable, scalable products which stand the test of time and don't have to be regularly disposed of or replaced, really does make sense. Real value is created by delivering solutions which last.

In today's challenging climate, businesses are introducing LEAN principles to deliver both agility and efficiency in their operations. With this in mind and as a result of in-depth research into their customer's challenges, Bott has developed a flexible and efficient workstation, allowing for customised applications and seamless expansion for when a business needs change. ■



**On stand 20C66 at this year's IMHX, Bott will be showcasing the newly developed ergonomic workstation along workplace storage products from with the heavy-duty, high-quality cubio range.**

## ▶ EUROTUBES UK

Quality and precision engineering experts, the company has been manufacturing its wire guide tubes from the Isle of Portland in Dorset for three decades. During this time, they have produced high volumes of bespoke designs and have created wire winding solutions for many satisfied customers from across the globe. With continued success and growth, Eurotubes UK recently invested in a new 580m<sup>2</sup> production area, dedicated to the

Through workplace fit-out experts 'Spaceway South', Bott recently provided an efficient, ergonomic workspace solution for Eurotubes UK.

manufacture and finish of their wire guide tubes.

The team's specific requirements were to create an efficient workflow process to deliver precision, consistency and repeatable quality across all of their products. They also needed ergonomic working areas for their valued engineers. Back-to-back, stand-alone workstations were designed, with flexible rear frame options incorporating lighting, storage and power. With added accessories, the heavy-duty workstations can be reconfigured at any time, enabling the company to remain responsive to customer's needs.

By investing in ergonomically designed workstations Eurotubes UK is promoting safety

and welfare in its working environment. Being modularly expandable with tilting and swivelling options, users can place accessories in the most comfortable positions that suit. With a wide range of complex designs being produced in very high-volumes, the intelligent design of the workstation guarantees them maximum efficiency and productivity. Also integrated into the production area are frame and pedestal benches with custom worktops, mobile and static drawer cabinets from the high-quality cubio range and versatile perfo storage solutions for small parts. ■



Designed to Perform, Built to Last



One Workstation – Endless Possibilities...



CUSTOM SOLUTIONS



ERGONOMIC DESIGN

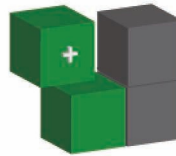

MODULAR



ZERO WASTE



Visit us at IMHX  
on stand 20C66

Configure your individual ergonomic workstation  
in 5 quick steps at [bottltd.co.uk/ergonomic](http://bottltd.co.uk/ergonomic)

# ▶ BS HANDLING SYSTEMS

## LOCATED: HALL 20, STAND F145

BS Handling Systems is a Leicester based materials handling and logistics company supplying modern conveyor, warehouse and storage solutions. As a full-service provider, BS Handling Systems offers complete turnkey project management including design, supply and installation. The company also manufactures its own range of conveyor systems for standard or bespoke systems.

With a wealth of experience in the logistics, sortation and automation environment, BS Handling Systems has installed many integrated conveyor and sortation systems. These projects have either been standalone or alongside pallet racking, shelving, garment handling systems and mezzanine floor solutions.

Recent projects have seen BS Handling Systems complete installations for a variety of clients across industry sectors including ecommerce giants, 3PLs, fashion retailers and the automotive industry. The Leicester based company has produced installations across the United Kingdom as well as Europe, Dubai and the Middle East.

The company's key account management strategy ensures contact continuity for every contract and project, from start to completion. With multiple engineering teams on the road throughout the UK, BS Handling Systems is able to back up installations with first-class servicing and call out cover, giving clients complete peace of mind. In addition to the UK, BS Handling System has also extended its service contract offerings to Europe as well as Dubai (remote).

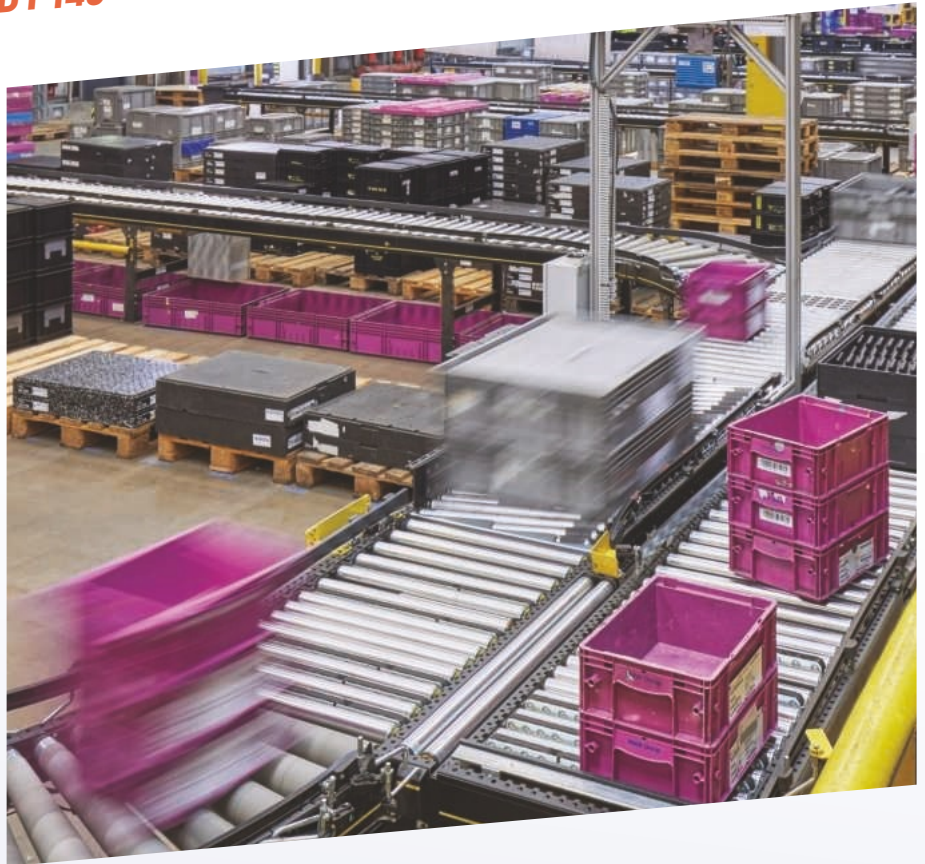

### BS HANDLING SYSTEMS EVOLVES

BS Handling Systems has recently completed works on its new head office in Leicester which features modern offices as well as an engineering facility which provides space for product manufacturing, testing, development and demonstrations.

The office build was designed and completed by BS Handling Systems and is a testament to its project management skills. Due to the success, the company plans to extend its service offering to clients to include refurbishment and new office fit out projects.

BS Handling Systems is passionate about the e-commerce industry and its environmental impact. As a result, future plans see the company becoming a UK distributor for a French company supplying recycled pieces of equipment. In addition to this, BS Handling has set a goal for the company to significantly reduce its carbon footprint within the next two years.

The new offices also feature a beehive, designed and made by the BS Handling Systems team, using recycled wood from the office refurbishment project. The initiative is to

house and protect an organic colony of bees to support the bee population and ecosystem.

As a forward thinking and employee focused company, BS Handling Systems has created a meditation room at the new office site. This is to support the wellbeing of employees and to promote a healthy work and life balance. The meditation room is part of BS Handling Systems' dedication to its social and environmental responsibilities.

In addition to the new head office, BS Handling has launched a new facilities management service provision to its client base. The company is now offering reactive/pre-planned maintenance and cleaning services with full 24/7 customer support across all industry and public sectors.

### IMHX- VISIT STAND 20F145

Visitors to the BS Handling Systems stand at the NEC, Birmingham can expect to meet members of both the materials handling and facilities management teams. Project managers will be welcoming people throughout the four-day logistics event to discuss any queries, quotes or potential projects. ■





# Insight & Clarity

## BS Handling Systems: Delivering the right solution for your warehouse

At BS Handling, our close knit design and engineering team has an outstanding track record of delivering innovative projects for **e-commerce**, **retail** or **3PL companies**.

Whether it's a large, complex turnkey solution or a small conveyor or storage system, **we can handle it.**

Our detailed planning and project management skills enable us to design and install multifaceted logistics and materials handling projects, **on time** and **in budget**.

So, if you're looking for the **right solution** to a challenging logistics project or a straightforward installation, pick up the phone or drop us an email:

**T: 0116 289 4958**

**E: [enquiries@bshandlingsystems.com](mailto:enquiries@bshandlingsystems.com)**

**[www.bshandlingsystems.com](http://www.bshandlingsystems.com)**



## ▶ DOOSAN

**LOCATED: HALL 19,  
STAND 19G80**

Doosan, the leading manufacturer of robust high-performance fork lift trucks, is to create six industry zones on its huge 658sq m stand at IMHX 2019.

Set to be one of the largest stands at the show, each zone – spanning Manufacturing, Construction, Agriculture, Transport, Warehousing and Aviation – will display Doosan's best-in-class solutions specific to the sector. The machines on show will be kitted-out with attachments appropriate to typical industry applications, offering visitors the chance to see the optimum handling solutions for enhancing performance in each industry.

The very latest counterbalance and warehouse truck models will be available to see, from the new feature-rich B15R-7 three-wheel and B45X-7 four-wheel series of electric forklifts, right up to Doosan's powerful, heavy-lifting diesel and gas models – including Doosan's giant 25 tonne capacity counterbalance forklift, the DV250S-7. However, there will be more than just counterbalance trucks to see.

In advance of the highly anticipated launch of its new range of warehouse trucks, Doosan will be offering a tantalising glimpse of what's to come by debuting three new models in the walkie and stacker powered pallet truck range – the BPL18/20S-7 with lateral drive, the BPM20S-7 with middle drive, and the BDL13S-7(H) double stacker. All three pedestrian operated trucks reflect Doosan's renowned design characteristics of compact functional form, high maneuverability, durability and rugged, reliable performance.

Also making its debut at IMHX in September will be Doosan's new versatile, 1,500kg capacity electric pallet truck – the BPSC15E-7 lateral drive, which has a built-in charger, long-life batteries and a compact chassis for extra maneuverability.

### RUSHLIFT GSE

As a rapidly growing part of Doosan's UK business, Rushlift GSE – the specialist airport ground support equipment subsidiary – will have a strong presence on the Doosan stand in the Aviation zone.

Representatives from the Rushlift GSE team will be available to discuss both long and short-term rental and leasing arrangements for airport ground support equipment.

In the Future Zone, visitors to the Doosan stand will be given the opportunity to see the future of materials handling, with a large-screen video display highlighting some of the transformational technologies Doosan is working on to drive productivity in the warehouse and in the yard. Automation and lithium-ion power are just two aspects of a journey of discovery that will highlight



the scale and scope of Doosan as a \$21bn global engineering business, involved in everything from power plants, engines and construction equipment to consumer goods.

In fact, see one of Doosan's lithium-ion powered trucks on the stand.

Electric power may be gaining wider acceptance in heavy-duty applications, but diesel is set to remain a significant power source for heavy handling tasks for some time to come. Demonstrating Doosan's commitment to clean diesel performance, the company is to show, for the first time in the UK, its new Euro Stage 5 engine – designed by Doosan to comply with the latest stringent EU emission standards.

Visitors to the stand will also get the opportunity to see, first hand, Doosan's new B15R-7 Series advanced 3-wheel electric counterbalance truck, with a capacity

range from 1.25 – 1.6 tonne. The compact and versatile truck is particularly well suited to the diverse needs of the small business – and being battery powered, offers the clean handling performance demanded by the food & drink sector.

### B45X-7 SERIES

Doosan's powerful new range of four-wheel electric counterbalance forklifts – the B45X-7 Series – will also be available for close inspection on the stand. The new model offers greater durability, enhanced productivity, increased visibility and an extensive range of safety features as standard.

With four new models covering a capacity range from 4.0 – 5.0 tonne, businesses

across a broad spectrum of industry – from manufacturing, wholesale distribution and food & drink to engineering, building supplies and transport & warehousing – will benefit from the improved capability, power and performance of Doosan's latest mid-range electric trucks.

Brian Grady, sales and marketing director at Doosan Industrial Vehicle UK, says: "This year at IMHX, we hope to demonstrate to our fast-growing UK customer base that Doosan has an established and rapidly expanding portfolio of materials handling equipment, designed and built to drive performance in just about every industrial sector. IMHX gives us a valuable platform to display our latest product advances, and allows visitors to see first-hand, the strong design features that make Doosan products the robust, reliable, high-performance workhorses favoured by a broad cross-section of industries." ■





# Powering the UK's forklifts for 15 years (and counting)

You simply can't get CEIL Batteries from anywhere else, as we're part of Exide Industries Ltd, India

Motive Power Batteries & Chargers Supply, Installation & Service



espexbatteries.co.uk

+44 (0) 2920 705453



## Dynamic Material Handling Solutions By Wanzl

- As a solution provider with consulting, development and manufacturing expertise, Wanzl Logistics & Industry stands for individual optimisation, efficiency and detail.
- Customers are supported from the very first step - from onsite consultation through to development, manufacture and implementation.
- Fundamental technological components within the dynamic order picking system working with the goods-to-person principle.
- Eliminates the need for time-consuming routes, increases order picking performance and improves employee accuracy.



The UK's largest intralogistics event  
24 - 27 September | NEC • Birmingham

01926 451951

enquiries@wanzl.co.uk

www.wanzl.co.uk

# Conveyor Solutions...

## IMHX New Product Launch

As the UK's largest conveyor manufacturer, Conveyor Units has provided integrators with effective conveying solutions for over 55 years. Satisfying the exacting demands of industry today requires a strategy of continual innovation and technological advancement. Visit us in Hall 20 for latest developments.



**IMHX 2019**  
The UK's largest intralogistics event  
24 - 27 September, NEC Birmingham

4 fully operational conveyor systems spread over 540<sup>2</sup>M Hall 20, Stand No's 20C60 & 20C80



# CONVEYOR UNITS

QUALITY • PERFORMANCE • RELIABILITY

Tel: +44(0) 1299 877541 | email: sales@conveyor-units.co.uk | www.conveyor-units.co.uk | www.conveyorrollers-uk.co.uk | www.conveyorspares.co.uk

Lineshaft Powered Roller Conveyor | 24V Motorised Roller Conveyor  
Belt Conveyor | Belt Under Roller Conveyor | Parcel Handling Conveyor  
Post & Parcel Conveyor | Flexible Conveyors | Gravity Conveyors

# ▶ INTERROLL

LOCATED: HALL 19, STAND J40

Conveyor technology expert **Interroll** is set to showcase a number of innovations at IMHX 2019. The company's DC Platform, which comprises a new RollerDrive EC5000 motorised roller, controls and power supplies, will be on display alongside the Pallet Flow range. Interroll's new DC Platform is a combination of 24V and 48V solutions that provide advances in automated conveyor technology and makes it possible to embrace the digital world, namely autonomous conveyors, predictive maintenance and more. The 48V specification is an optimum solution because it allows users to utilise fewer power supplies and more cost-effective wiring, thus reducing installation time and overall system cost. With Interroll's new RollerDrive EC5000, users will be able to choose between different power levels, depending on the

application. For instance, 35W and 20W can be deployed for light-duty applications, or 50W for heavier loads. Notably, RollerDrive EC5000 is backwards-compatible with current controls and power supplies, which means it is easy for customers to retrofit their existing system. Thanks to an advanced CANopen Bus, the latest RollerDrive EC5000 offers several benefits: it is not only a standard drive but is capable of positioning items in an accurate fashion. Also being promoted at IMHX for the first time in the UK will be the Interroll Modular Pallet Conveyor Platform (MPP), a comprehensive integrated solution for pallet handling. When combined with Interroll's Pallet Flow, MPP gives system integrators the possibility to provide customers with a proven, high-quality solution for the entire flow of pallets through manufacturing

plants and distribution centres. MPP, which is designed to be reliable, versatile, energy-efficient, safe and scalable, is a combination of pallet conveyor modules (roller or chain conveyors) and specialty conveyors, such as transfers, lifts and turntables. ■

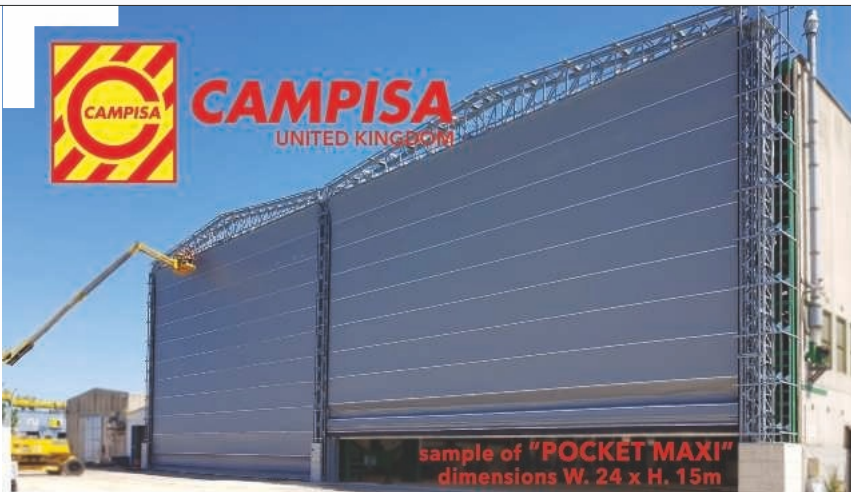

**SPIRAL DOORS**

**VISIT US AT THE IMHX 2019**  
The UK's largest logistic event

**NEC • Birmingham**  
**24/27 September**  
**hall 19 stand 40**





**CALOR**

BioLPG

TAKE YOUR  
CO<sub>2</sub> TO A  
WHOLE NEW

**LOW**

BioLPG, exclusively from Calor, reduces emissions – at no extra cost. **It's a no-brainer.**

Find out how much you could save by visiting [calor.co.uk/fit](http://calor.co.uk/fit)

# COMBILIFT AND AISLE MASTER

LOCATED: HALL 18, STAND L125

With around 15 exhibits at this year's IMHX, visitors to the four Combilift and Aisle Master stands will be spoilt for choice. Some of the company's larger products such as the Combi-SC Straddle Carrier will be on show in the outdoor area, and the stands just inside the entrance to Hall 18 will feature a wide variety of customised, innovative handling solutions that are hallmarks of this Irish manufacturer. Two new products are making their UK show debuts at IMHX: the Combi-PPT powered pallet truck and the Combi-CSS Container Slip-Sheet.

The Combi-CSS was designed for quicker and easier mechanised loading of long products into containers, addressing the challenges associated with the combination of forklifts and manual labour often required for this application. It is a 30,000kg capacity low free-standing platform with a dual-directional motor-driven pulling mechanism, on which a steel sheet rests. A full load can be prepared on the sheet which is then guided into the container and a 20' container can be loaded in just three minutes. When fully loaded, a hydraulic rear barrier gate swings across the container opening and is locked in place. This holds the material within the container while the metal sheet is slipped out from underneath it.



Combilift managing director and CEO Martin McVicar says: "I am confident that companies dealing with containers will embrace this new product, as they did the Straddle Carrier, due to the improvements it offers in terms of safety, speed and efficiency."

The Combi-PPT, which won the Safety Category of the FLTA Awards for Excellence 2019, is a high-performance pedestrian operated powered pallet truck, with capacities from 3,000kg up to 16,000kg. It enables very large and bulky products to be manoeuvred with ease in confined spaces, ensuring maximum safety when working in areas where other personnel are present, in production plants for example. It features Combilift's unique, patented multi-position tiller arm that is used in all the company's pedestrian models. This incorporates tiller and operator offset position with the touch of a button, allowing for excellent visibility and reducing crush risk to the operator.

Exhibits will also include small pedestrian stacker trucks, variants of the original multidirectional C-Series, stand-on narrow aisle forklifts, the heavy-duty XL range, Combi-CB counterbalance design 4-way models and Aisle Master articulated forklifts.

McVicar comments: "We have an even larger stand space than at the last event which allows us to showcase our ever-growing range and we will be sticking to our very successful IMHX formula – a mix of new products, live demos and entertainment!" ■

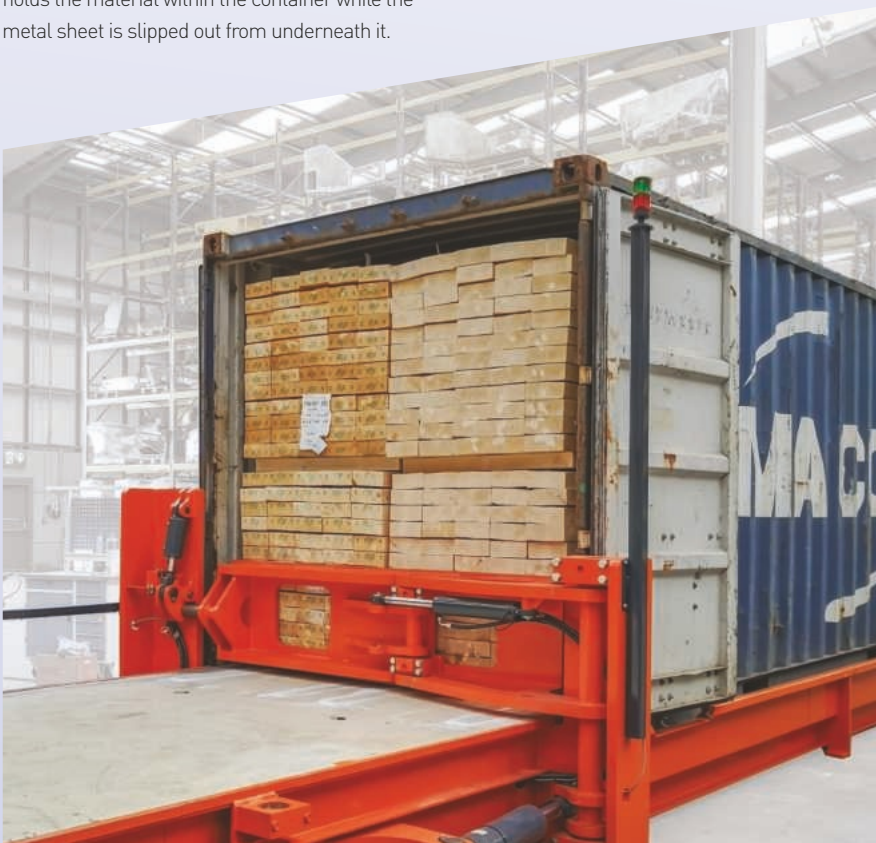



# COMBiLiFT

LIFTING INNOVATION

**IMHX<sup>TM</sup> 2019**  
The UK's largest intralogistics event  
24 - 27 September | NEC · Birmingham

- ✓ SAFER PRODUCT HANDLING
- ✓ IMPROVED STORAGE CAPACITY
- ✓ INCREASED PRODUCTIVITY



**SAFETY | STORAGE | EFFICIENCY**

+353 47 80500 

 [combilift.com](http://combilift.com)



**▶ QTS**  
**LOCATED: HALL 6, STAND E245**

QTS is one of the UK's leading manufacturers of wire mesh decks. Its mesh decks range EASYShelf is used daily in warehouses up and down the country. QTS began supplying wire mesh decks into the UK in 2006, with the first installation on behalf of Debenhams in Peterborough, which consisted of 2,000 units. At the time, these were supplied in partner factories in China and continued being the case until 2014 when it embarked on a brave mission to re-shore our manufacturing to the UK.

Since 2014 QTS has invested year-on-year into the manufacturing process for mesh decks. These investments have seen the project range for mesh decks expand exponentially to cater for the diverse storage solutions seen in today's modern warehouses. Based within the logistics heartland of the East Midlands and positioned right on the doorstep of junction 28 of the M1; it is the ideal location to serve the ever-expanding nationwide customer base.

QTS never merely aims to produce a

product but consult with our customers to design the right product and then deliver it within industry best lead times. The company's success in being the only leading UK manufacturer of mesh decks sometimes overshadows its other product ranges, again manufactured in the UK. QTS' Anti-Collapse system, RACKGuardian has been supplied extensively throughout the UK in both standard 50x50mm mesh but also in a 25x25 mesh for areas storing aerosols or high value goods.

With the continued investments into new machinery, the company is pleased to be re-launching at IMHX 2019 its new and much improved STORGuard system. The customer experience has been centric to many of these design changes with the most noticeable one being ease of installation, with less bolts to tighten up.

Since its inception in 2003 QTS has developed by listening to its customers. These comments provide the high level of motivation to make its solutions better each year. ■



**THE EXPERTS IN MESH.**

Combining the collective experience of our staff and our world class manufacturing facility in Nottinghamshire, you will be hard pressed to find another company like QTS. Our team of experts includes individuals with extensive backgrounds in deck design, secure partitions, pallet racking and project management.

Stuck on a project? We have the solution. Pay us a visit on stand, and put our team to the test.



01455 633567  
 enquiries@qts-ltd.co.uk

WE'RE EXHIBITING AT  
**IMHX 2019**  
 STAND 6E245



**EFAFLEX**  
**LOCATED: HALL 19, STAND J20**



Once again EFAFLEX, global market leaders in the design and manufacture of high-speed doors will be exhibiting at this year's IMHX. This event is the ideal opportunity to showcase the latest product innovation designed specifically with logistics in mind; speed, safety and cost reduction.

On display will be the Materials Handling and Logistics (MTL) door that can be configured as either an access obstacle (FTO) or an access prevention (FTM) system depending on the application, and can be supplied with a number of drive types options.

The MTL has proved exceptionally popular within logistics and warehouse environments. This fabric roll-up door is perfect for intense commercial and industrial processes and can operate at 250,000 cycles per year, to reduce the frequency of service and maintenance checks and minimise costly downtime.

In addition, EFAFLEX will be demonstrating their unique spiral design. This premium quality engineered product was introduced over 25 years ago and remains unrivalled as the world's fastest vertically opening high-speed door. With opening speeds of up to 4 metres per second, this fast action door helps reduce exposure to the elements, and with its thermal laths can help reduce client's energy usage by up to 50%.

The EFAFLEX team will be demonstrating their Sales App which enables clients to see a 3D render of their design at the click of a button. They will be joined on day one of the show by EFAFLEX's BIM expert who can advise visitors on the latest strides EFAFLEX has made in this area.

Seeing is believing. Come and see EFAFLEX in action. The world's fastest vertically opening high-speed door on stand 19J20 or visit [www.efaflex.co.uk](http://www.efaflex.co.uk)



**EFAFLEX**   
*safe high-speed doors*



See us  
on stand  
**19J20**

**IMHX** 2019  
The UK's largest intralogistics event  
24 - 27 September | NEC • Birmingham

**Efficient, Effective,  
Engineered...**

**EFAFLEX are world leaders across multiple markets in high-speed door applications.**

Whether for use within warehouse, logistics, cleanroom, food preparation or machine protection applications, EFAFLEX spiral, roll-up and folding doors define the standard in German premium quality engineering. Such quality ensures a long service life and consistently low operating costs.

- Safety • Speed • Reliability Quality**
- Environment • Design**



**Phone:** 01952 582641  
**Email:** [marketing@efaflexuk.com](mailto:marketing@efaflexuk.com)  
**Web:** [www.efaflex.com](http://www.efaflex.com)

# ▶ ONES TO WATCH

## GEBHARDT

Gebhardt GridPick is the new system for enhanced order picking efficiency in manual warehouses. It consists of freely navigating driverless transport robots with an integrated Gebhardt StoreWare warehouse control system.

The order picker is guided through the warehouse and through the picking process in a route-optimised manner. The picked articles are verified using a barcode scanner integrated into the vehicles and sorted into the payload area. The employee has their hands free, is not required to shift heavy loads, and

the distances and times spent searching for items are significantly reduced.

Working together with the GridPick robots is intuitive. The GridPick is regarded as a "Co-Bot" – a cooperative, collective and collegial robot – which supports and eases the burden on employees by enhancing efficiency within manual warehouses.

The employee uses a tablet as the user interface, which is attached at eye level. ■

Located: Hall 6, Stand E240

## TRIATHLON BATTERY SOLUTIONS

Triathlon Battery Solutions specialises in battery systems for use in electric forklifts and pallet trucks, electric industrial trucks, mobile lifting platforms and other electric vehicles. Through its incomparable experience and expertise, the company has developed the Triathlon Lithium Ion Battery systems. These products enable end users to meet the requirements of long operating times, giving customers the ability to work around the clock. The company are exhibiting for the first time at IMHX to present its battery technologies for motive power applications, intelligent charger technologies and battery management systems at stand 6D205. ■



Located: Hall 6, Stand: D205



## HOPPECKE INDUSTRIAL BATTERIES

Hoppecke's stand will look to reinforce its credentials in lead acid technology by unveiling the new trak | uplift battery. Featuring new active carbon, which allows precisely matched active materials to deliver higher current discharge characteristics along with an improved fast charging capability, the trak | uplift improves service life. Available as a cost-optimised basic solution, it is purpose-designed so that additional components, such as trak | air electrolyte circulation, can be retrofitted at any time.

Hoppecke will also discuss the advantages of its new high efficiency trak | charger HF Premium, which features touch screen controls and is suitable for use with lead-acid, gel and lithium-ion batteries.

IMHX visitors will also find out how to reap the benefits when upgrading their materials handling equipment from traditional lead acid batteries to Hoppecke's innovative lithium-ion technology. ■

Located: Hall 6, Stand E200

## DEMATIC



Located: Hall 18, Stand N30 and TL4

Dematic – a leading supplier of integrated automated technology, software and services to optimise the supply chain – will invite visitors to step into *the future of intelligent logistics* on stands 18N30 and TL4 at IMHX 2019.

Guests to the stand will have the opportunity to gaze into the future. Speakers from Dematic's Robotics Centre of Excellence will venture into the realms of intelligent logistics, highlighting some of the exciting new technologies that are under development – offering a glimpse of tomorrow's solutions. Insights will span from AI to robotic vision systems for single item picking.

Visitors to the Dematic stand will also be taken on a journey of enlightenment around some of the very latest automated logistics solutions available today. These include a fully-working example of Dematic's leading Pouch Sorter system, capable of solving the most challenging fulfilment and returns problems for retail ecommerce; an on-stand display of the ultra-dense robotic storage system, AutoStore and a live demonstration of Dematic's Piece Picking Robots. ■



**ELOKON**  
**STAND: HALL 6, STAND E214**

Elokon, the developer and supplier of safety and assistance systems for industrial vehicles, forklifts, AGVs and cobots will be showing two of its flagship products at IMHX 2019 as well as unveiling new developments in its production pipeline. Including intelligent wearables, these products are all based on the use of smart technology to make the warehouse a safer working environment.

Visitors will be able to see Elokon's safety system ELOprotect. This ensures that forklifts operate at a safe distance from personnel in VNA warehouses to prevent accidents between trucks and pedestrians, as well as truck-on-truck collisions. Consisting of evaluation electronics, laser scanners and display and operating modules, it is automatically activated when a truck enters a narrow aisle and if a person, other forklifts or obstacles are detected it emits warnings and can bring the vehicle to a complete standstill. ELOprotect enables faster forklift operations for more productive handling cycles and allows the simultaneous use of more than one VNA truck in an aisle whilst

adhering to the strictest safety guidelines.

Another award-winning product on show is ELOshield, a UWB-based proximity detection system with flexibly configurable electronic protective zones around personnel and vehicles. Modules attached to the trucks and carried by personnel monitor their movements, detect their location and warn them if they get too close to each other. Various ELOshield versions are available such as a fixed site version which keeps a safe eye on accident-prone areas such as busy aisle intersections. A further option

enables the creation of flexible speed zones which automatically limit the speed of trucks, in production areas for example.

A further development is the ELOfleet4 forklift fleet management system, controlled by an app on a smartphone or tablet of the customer's choice. All Elokon solutions are OEM independent and can be installed and also retrofitted on fork lift trucks of any type, brand, age or drive type. The company also offers safety consultation services to further reduce risks in intralogistic and industrial operations. ■



# SAFETY AND ASSISTANCE SYSTEMS FOR FORKLIFT TRUCKS

**ELOKON**

ELOKON's OEM-independent solutions for industrial vehicles, AGVs and cobots reduce the risk of accidents in the warehouse, safeguarding your workforce, your equipment and your facilities:

Personnel protection in narrow aisles - **ELOprotect**

Pedestrian detection in hazardous areas - **ELOshield**

Automatic forklift speed reduction - **ELOspeed**



[www.elokon.com](http://www.elokon.com)

**IMHX<sup>TM</sup> 2019**  
 The UK's largest logistics event  
 24 - 27 September | NEC - Birmingham

**SEE US AT IMHX  
 BOOTH 6E214**

## CURTIS INSTRUMENTS

Curtis UK has developed an extended range of products that help OEMs and dealers to further enhance the safety and performance of their ranges, some of which will be on display at IMHX 2019.

A wide range of coloured LED safety lighting, recently re-launched at 20% lower costs, will be on show at Stand 20F75.

Meanwhile, Curtis UK will also be displaying its newest high frequency charger, the TEMPO. Tempo is small, powerful and flexible. Multi-

voltage, with a wide ampere hour rating (36-72V, 10-130A), in just two suitcase sized three phase models. Just two chargers fit dozens of battery applications, including lead acid, AGM and Gel.

Our stand team will include charging solution experts and members of our applications engineering team, as well as senior members of the management team, including our managing director, David Wilkes. ■



Located: Hall 20, Stand F75

## BITO STORAGE SYSTEMS

At IMHX 2019, one of the UK's leading storage solutions providers BITO Storage Systems will be displaying its ability to provide a comprehensive set of products and solutions in three groupings – small parts picking; bulk storage using pallet live systems; and general storage and order picking.

Among the innovative solutions featured across the three groupings of the impressive stand –BITO's biggest ever at a UK exhibition – will be pallet, carton and pallet live systems; shelving; bins and containers; and the LEO Locative driverless transport system. BITO can also supply supporting products such as mezzanines, warehouse trucks, signage and guarding.

A new highlight will be a demonstration of how a section of its increasingly popular multi-tier shelving is constructed. ■



Located: Hall 20, Stand E75

## SWISSLOG

At IMHX 2019, leading warehouse automation and software provider, Swisslog, is set to present innovations based on self-optimising, modular, software-driven and robotic technology.

Visitors to the Swisslog booth can also learn about the next generation of the ItemPiQ robot order picking system, and how it can be linked to material handling solutions such as AutoStore.

ItemPiQ is highly versatile for easy adaptation to the customer's changing product palette. Aided by artificial intelligence, the system "learns" the optimal picking method for each new item. ■



Located: Hall 18, Stand N20

## SNAPFULFIL

Synergy – the company behind the award-winning SnapFulfil WMS – is debuting its innovative robotic fulfilment cart at IMHX.

SnapCart is an autonomous mobile robot (AMR) that can significantly reduce pickers' daily walking distance from as much as 15 miles to 1 mile.

Adopting a 'man-to-goods' approach to multi order picking and automation, SnapCart is a low-cost and low-risk solution. Warehouses can gradually integrate the collaborative robots without making any costly infrastructure changes.

Designed to enhance picking, rather than replace warehouse operatives, SnapCart has an easy-to-use interface, so staff can be trained within minutes. Carts can be added as needed to manage start-up costs and scalability. ■



Located: Hall 6, Stand E178

## MENTOR FLT TRAINING

Mentor FLT Training, the UK's leading provider of forklift and safety management training, has announced that it will be running free taster sessions of its new Managing Forklift Operations course at IMHX 2019 this September.

To help busy managers fit training around daily demands, the course will be available in two formats: as an online e-learning course – the first of its kind in the UK – and via face-to-face delivery.

Mentor is giving IMHX visitors the

exclusive opportunity to get a first look at the course. Sessions will take just 10 minutes of visitors' time but will provide valuable insight into course content.

Managing Forklift Operations is AITT accredited, and specifically developed by Mentor for managers and supervisors responsible for overseeing forklift use on site. ■

Located: Hall 20, Stand C89

**As Macmillan's 'World's Biggest Coffee Morning' takes place on the final day of IMHX, Swisslog will also be showing support for this very worthy cause. For every person that signs up for a complimentary logistics consultancy session on Friday 27th September, Swisslog will donate £5 to Macmillan and ensure plenty of robot-themed cakes are on offer!**



## ▶ HI-LEVEL MEZZANINES LOCATED: HALL 18, STAND M24

Hi-Level designs, manufactures and installs bespoke structural steel mezzanine floors across the UK and Europe. It provides a complete turnkey solution, from initial quotation to all stages of mezzanine floor production and installation, with experienced project managers overseeing each project to ensure all runs smoothly.

### PRODUCTS AND SERVICES

Depending on your load requirements, usage and budget, it offers a range of flooring from particle board and steel decking to concrete composite floors.

Whether you require a robust steel walkway, a heavy-duty concrete floor to minimise deflection, an easy clean waterproof surface or a lighter weight particle board floor for pallet storage, Hi-Level has the solution, as its staircases, edge protection and pallet gates can also be customised to match brand colours.

Specialist Structural Engineers design each floor to its customers' exact requirements, ensuring Hi-Level keeps steel to a minimum to help keep costs lean, while ensuring full compliance to official design codes. Rather than over-engineer its own floors unnecessarily, the company finds creative solutions for your operational challenges.

### RAISING THE STANDARD

The philosophy of Hi-Level has remained consistent over the past 28 years – to deliver high quality, value-engineered mezzanine solutions and keep people safe while working at height. Its ethos is not to cut corners and put a robust framework in place to ensure the quality and design of its bespoke product is fit for purpose and meets all relevant British and European standards. The company is externally audited and has certifications including CE Mark, ISO 9001, ISO 14001 and OHSAS 18001.

Optimising space in warehouses and distribution centres is Hi-Level's forte,



according to the company, and they are proud to have delivered mezzanine solutions for major brands including national retailers and global logistics companies. Whether operations need to reconfigure existing space or fit out new premises, the company has the experience and expertise to assist. ■

**Visit stand 18M24 at IMHX to meet Hi-Level's friendly sales team, Find out how it can help future proof your premises while minimising operational disruption.**

# Solving capacity challenges since 1991



[www.hi-level.co.uk](http://www.hi-level.co.uk)

Put our **mezzanine experts** to the test to help you best **optimise your warehouse**

Visit us  
on stand  
18M24 at  
IMHX

**hi level**<sup>TM</sup>  
raising the standard

# ▶ HONEYWELL

**LOCATED: HALL 19, STAND K105**

When it comes to logistics and supply chain management, efficiency is a critical component in keeping pace with customer demands and outperforming competitors. With online sales growing by the second, e-commerce, post and parcel, and wholesale distribution operations must seize every opportunity they can to increase efficiencies across their organisations.

For more than 100 years, we have helped companies automate their material handling systems to be more efficient, more productive and more profitable. Today, that tradition continues with automated sortation systems and voice solutions that streamline processes, optimise workflows, and get products from warehouses to customers' doorsteps faster than ever before.

## RELIABLE AND DEPENDABLE

We draw on our vast sortation experience and thousands of installations to provide sortation systems that deliver efficient, high-performance automated distribution and fulfillment operations for retailers, manufacturers and logistics providers around the world.

Our sortation systems accommodate the widest range of product size, shape and capacity requirements in the industry. Optimised for the most demanding applications, these systems offer the highest throughput rates at minimal speeds, preserving product integrity and key system components for years of reliable, low-maintenance operation.

Each sortation system is designed to ensure gentle handling and smooth product flow while maintaining low noise levels and consuming less energy. Systems are equipped with comprehensive software and controls to optimise operation, calibrate machine logic, and quickly diagnose issues to minimise downtime.

## PROVEN RESULTS

Companies like Dick's Sporting Goods and Kirkland's trust the sortation systems because of its mission-critical reliability, durability and proven ROI.

When Dick's Sporting Goods doubled the size of its facility from 360,000sq ft to 725,000sq ft, the company upgraded its sortation and conveyor system by adding single- and dual-sided, high-speed IntelliSort sliding shoe sorters and a high-speed IntelliMerge



system. The new system delivered a 20% increase in productivity in the facility's break-pack area and a 10% increase in productivity in the facility's receiving area.

Honeywell helped Kirkland's redesign its sortation system to accommodate surging growth. The redesign, which included adding an IntelliQ accumulation line and two IntelliSort shoe sorters, increased outbound throughput capacity, reduced cycle turnaround time from receipt to shipment by 75%, and enabled Kirkland's to accommodate future growth.

## A VARIETY OF TAILORED SOLUTIONS

Every company has different needs, objectives and challenges. That's why the company provides sortation systems tailored to any market or application. It offers solutions for a wide variety of throughput requirements and product types and sizes, from malleable polybags to rigid totes and cases.

With the widest range of sortation options in the industry from which to choose, companies can maximise throughput with a system optimised to meet their operational needs for years of reliable, low-maintenance operation.

## VOICE-ENABLED PROCESSES

Driving profitable growth and streamlining existing processes to reduce costs or accommodate future growth doesn't always require significant changes to a company's infrastructure. Warehouses and distribution centres can reduce operating costs and

increase employee productivity and accuracy with easy-to-implement voice solutions.

Honeywell Voice solutions provides warehouses and distribution centres with streamlined, best-in-class business processes to take organisations to the next level of operating efficiency.

And because voice solutions replace paper and handheld devices, such as tablets and barcode scanners that require manual data entry, they increase productivity, accuracy, safety and employee satisfaction. The technology has helped customers increase productivity by up to 35% and improve accuracy by decreasing error rates by 50%. ■

▶ VISIT HONEYWELL  
INTELLIGRATED ON  
STAND 19K105

To learn more about our sortation and voice system solutions, visit IMHX booth 19K105. Honeywell Intelligrated representatives will be on hand to discuss common logistics and supply chain challenges and demonstrate our extensive line of sorters, loop sorters, conveyor diverts, and voice- and light-directed solutions.

It will also discuss how its Honeywell Voice solutions can help boost productivity, rapidly scale operations, and redistribute labour where it's needed most. ■



# **SORTATION CHALLENGES SOLVED.**

Whether 25 items per minute or 25,000 items per hour, increase your productivity with the broadest range of sortation solutions in the industry. **Visit us at IMHX, stand 19K105.**

**THE FUTURE IS WHAT WE MAKE IT** |

**Honeywell**  
**I**ntelligrated®

© 2019 Honeywell Intelligrated. All rights reserved.

# ▶ HYSTER EUROPE

LOCATED: HALL 19, STANDS K120 & K125

Hyster is one of the leading global brands of materials handling equipment and one of the best-known names in the industry. Hyster Europe offers a comprehensive range of material handling equipment, from the largest container handlers and reach stackers, to nearly every type and size of industrial fork lift truck, to special warehousing equipment.

## IMHX 2019

At IMHX, Hyster Europe will be showcasing its 360-degree solutions for logistics operations, including those to support the construction materials and paper supply chains.

Experts from Hyster Europe, and its UK dealer Briggs Equipment, will be on hand to discuss how to manage costs and optimise operational efficiency by matching the right Hyster trucks and solutions to application specific materials handling needs.

## 360-DEGREE SOLUTIONS

Whether operations are handling bricks, blocks, aggregates, concrete precast or other building materials, dusty, dirty working conditions are the norm, so the driver experience matters. Hyster lift trucks use intelligent design to assist operators, with ergonomically designed cabs that provide good driver awareness as standard, alongside, flashing beacons, back-up alarms and reflective markings. Flashing front/reverse lights and pedestrian awareness spot lights may be used to further support awareness.

At IMHX, a Hyster Fortens lift truck with a 3.5 tonne capacity will be on display, fitted with additional features to further support driver awareness. This includes Hyster object detection solutions to help support drivers in identifying nearby hazards, in turn potentially avoiding costly damage, and Hyster camera systems, which may help support visibility in certain applications, making it possible to view the immediate area surrounding a truck and the load.

Hyster Europe also offers a range of mobile weighing solutions so operators can



accurately weigh loads during transport, rather than transporting each load to a static scale, saving valuable time and increasing efficiency. To further support efficient operations in the construction materials supply chain, the Hyster solutions team can combine the weighing system with speed limitation technology.

With either roof sensing speed limitation, or RFID speed limitation located in the warehouse floor, applications can automatically restrict the speed of the trucks when loads reach a certain weight. This can in turn help minimise damage to the truck, load or warehouse infrastructure.

## PAPER HANDLING

In busy paper handling operations, intelligent lift truck design is essential for preventing load damage and maximising reliability. Hyster lift trucks include innovative features to keep paper moving through the supply chain, preventing product contamination and wrapper damage while minimising the damage caused by shock loads.

An ideal truck model in paper handling applications is the intelligently designed Hyster J5.5XN-6 electric lift truck, which will

be on display at IMHX. This powerful, high capacity electric forklift provides excellent manoeuvrability in the tight confines of paper production and storage applications, alongside a low cost of operation.

The model that visitors to IMHX can see has also been specially adapted to meet the needs of customers in the paper industry. It features a custom mast that includes a variable spacer to enable paper rolls to be handled using a reel clamp attachment without the shift in load centre or reduction in residual capacity that can be encountered.

## 360-DEGREE SERVICE AND SUPPORT

The global network of local Hyster distribution partners, such as Briggs Equipment, provide full service and support, adapting to the needs of specific industries and applications. From providing guidance on reducing maintenance or fuel costs and optimal fleet management, to after-sales service to maximise uptime and productivity, Hyster dealers have 360-degree expertise to enhance demanding materials handling operations.

Learn more from Hyster Europe at stand 19K120 at IMHX or visit Hyster distribution partner Briggs Equipment at stand 19K125. ■



# INTELLIGENT SOLUTIONS FOR TOUGH HANDLING CHALLENGES. CHOOSE HYSTER.<sup>®</sup>



**STRONG PARTNERS.  
TOUGH TRUCKS.<sup>™</sup>**



**IMHX<sup>™</sup> 2019**  
The UK's largest intralogistics event

**JOIN US AT IMHX, BOOTH 19K120  
24-27 SEPTEMBER, NEC BIRMINGHAM**

**EXPLORE HYSTER'S FULL RANGE  
OF SOLUTIONS AT:**

**WWW.HYSTER.EU**



HYSTER, the Hyster logo and STRONG PARTNERS, TOUGH TRUCKS.<sup>™</sup> are registered trademarks, service marks or registered marks in the United States and certain other jurisdictions.

# ▶ ONES TO WATCH

We continue previewing some of the key names to look out for at this year's IMHX, 24-27 September, NEC Birmingham.

## RTITB

RTITB will launch its revolutionised Materials Handling Equipment training accreditation services at this year's IMHX event in Birmingham.

Visitors to RTITB's stand at the event will be among the first to learn about its new and improved training accreditation service providing employers with a cost-effective way to manage and deliver their MHE training.

Also at the event, RTITB will provide an exclusive preview of its new portal for

accredited organisations, MyRTITB.

The new portal gives RTITB partners everything they need to deliver training in one easily accessed, user-friendly location. Members will be able to upload training onto NORS, the centralised validation, registration and certification scheme for RTITB accredited training which helps ensure that re-training and re-testing takes place at suitable intervals to improve safety and efficiency. Users will also be able to analyse training completed per site or per instructor and send electronic reminders regarding qualifications which are about to expire. ■



Located: Hall 20, Stand C86

## JCB

JCB will be showcasing models from the multi-award winning Teletruk range of telescopic lift trucks, including the newly launched JCB 30-19E - the first electric-powered machine in the Teletruk range.



Located: Hall 18, Stand N25

The JCB Teletruk has revolutionised materials handling operations in builders merchants, ports, recycling centres and industrial facilities around the world since it was first unveiled in 1997.

With its iconic telescopic forward reach boom, the JCB Teletruk was developed as an alternative to the conventional lift truck, which, of course, has a front-mounted mast that raises and lowers loads only vertically.

The forward reach functionality makes the Teletruk the ideal choice of lift truck at sites where containers, curtainsided trailers, vans and other delivery vehicles have to be loaded and unloaded quickly, safely and efficiently.

Outside, the Teletruk can load or unload a curtainsided trailer in under 30 minutes and requires 30% less space than conventional counterbalanced trucks to work in. ■

## ENERSYS

EnerSys will showcase the latest advances in Lithium-ion and Thin Plate Pure Lead (TPPL) motive power battery technology for material handling applications at IMHX. The exhibition will witness the UK debut of NexSys PURE batteries, which utilise a combination of advanced carbon and TPPL technology to provide reliable power without the requirements of watering, equalising and battery changing.

Through the use of both TPPL and advanced carbon, NexSys PURE batteries provide for a higher cycle life in applications requiring regular opportunity charging. The launch of NexSys PURE completes the NexSys range, which will also include NexSys iON batteries. The batteries come equipped with an integrated battery management system in the control module that provides protection, control and communication to the charger and truck.

In addition to showcasing its latest advanced batteries, EnerSys will reveal how companies can improve efficiency and cost savings by gaining a deeper insight into the power management of their electric material handling vehicles. ■



Located: Hall 20, Stand D148

## BYD

The line-up of BYD warehouse trucks at IMHX includes the new BYD PTW20S Pedestrian Pallet Truck; featuring a compact design, great manoeuvrability and an on-board charger as standard enabling charging during transportation, the agile PTW20S is ideal for safe, efficient and silent urban on-truck deliveries as it is relatively lightweight at 500kg, yet offers a generous 2000kg lifting capacity.

It will be joined on-stand by the BYD PTP20S Stand-On Pallet Truck; the second-generation PTP20S is a completely re-engineered high-speed stand-on pallet truck, featuring superior stability, flexibility, and a floating driving system for optimal traction. The compact BYD PTP20S has foldable side bars and platform so can be used in pedestrian mode



Located: Hall 20, Stand E147

when operating space is restricted.

Sharing the same leading-edge Iron-Phosphate battery technology, examples from BYD's comprehensive range of counterbalance forklift trucks will also be on display on the stand at IMHX. These include the IFOY Award-winning ECB18C 3-wheel counterbalance forklift and ECB25 4-wheel counterbalance forklift. ■





# Fen-Bay Services

THE LOADING BAY AND INDUSTRIAL DOOR SPECIALISTS

We are delighted to be attending the **IMHX** at the NEC on **24-27th September**, and look forward to welcoming both new and valued clients to visit us at our stand **6C240**.

Fen-Bay have always been forward thinking, with our focus being on innovation and listening to our client's needs to provide the best solutions. With Health & Safety being at the forefront of everything we do. After celebrating a recent period of growth, we are now even more capable of delivering a sustainable service to meet our customer's requirements. Fen-Bay Services now have over 120 members of staff and have fully trained engineers strategically located throughout the country to provide full UK coverage, for both reactive and project works.

We will be bringing several pieces of our key equipment to display and demonstrate the diversity that Fen-Bay can offer as well as information you require on all services we can provide.

FBS cater for both small and large projects and also offer bespoke design solutions for individual customer's requirements, whether it be a new build, refurbishment project, maintenance or a simple repair, Fen-Bay aim to provide 100% customer satisfaction at all times.

Fen-Bay Services Ltd trading for over 25 years and utilising the latest technology and innovative products have grown to become one of the leading nationwide providers of the blow services and equipment:

- **Energy Saving Loading Bays**
- **Industrial Doors**
- **High Speed Doors**
- **Cleanroom Doors**
- **Double Deck Loading Bay Solutions**
- **Scissor Lifts**
- **Scissor Lift Refurbishment**
- **Gates and Barriers**
- **Turn Key Solution - One contractor**
- **24/7 Emergency Repair Nationwide inc PPM Contract**

**Please don't hesitate to call our sales team today on 0800 533 5817 or email [sales@fen-bayservices.co.uk](mailto:sales@fen-bayservices.co.uk) who would be delighted to discuss how we can help you or book you into IMHX as one of our VIP guests.**



## Fen-Bay Services

THE LOADING BAY AND INDUSTRIAL DOOR SPECIALISTS

- **Energy Saving Loading Bays**
- **Industrial Doors**
- **High Speed Doors**
- **Cleanroom Doors**
- **Double Deck Loading Bay Solutions**
- **Scissor Lifts**
- **Scissor Lift Refurbishment**
- **Gates and Barriers**
- **Turn Key Solution - One contractor**
- **24/7 Emergency Repair Nationwide inc PPM Contract**

**[www.fen-bayservices.co.uk](http://www.fen-bayservices.co.uk)**

**Come and visit our Stand at IMHX 2019 to discuss any requirements you may have.**

**24 - 27 September 2019  
NEC Birmingham, UK**



# CELEBRATING EXCELLENCE



The Logistics Awards take place on Thursday 26 September 2019 at The Vox, Resorts World, Birmingham, during IMHX. Join us to find out who this year's winners are.

## CONGRATULATIONS TO THIS YEAR'S FINALISTS:

In association with SHD Logistics magazine, The Logistics Awards recognise the most impressive achievements throughout the industry. Since its inaugural edition in 2014, the event has attracted senior professionals from leading retailers, manufacturers and logistics operations.



Over 500 senior professionals from leading retailers, manufacturers and logistics operations are expected to attend The Logistics Awards dinner, which will be held at the VOX Conference Centre, Resorts World at the NEC Birmingham.



The Logistics Awards 2019 will feature 12 award categories including the Environmental Award, Technology Transformation Award and – new for 2019 – a Well-being Initiative prize. "The Logistics Awards recognise intralogistics and supply chain excellence and will be an important part of IMHX," says IMHX 2019 event director, Rob Fisher. ■

### FUTURE SKILLS AWARD

- Business on the Move
- Kuehne + Nagel with NOVUS
- Dynamic Medical Logistics
- Core Management Logistics
- ArrowXL
- Clipper Logistics with Sheffield Hallam University, Derby University and Superdry

### ENVIRONMENTAL AWARD

- DP World London Gateway
- McCulla (Ireland)
- Gnewt by Menzies Distribution
- Silentnight
- Hermes
- Unipart Logistics with Sky
- Heineken UK
- Clipper Logistics
- PD Ports

### GROWTH AWARD

- West Road Haulage
- Best Food Logistics
- Cygnia Logistics
- Clipper Logistics with LoveCrafts
- Oakland International
- BT Final Mile
- Kidds Transport
- Carousel Logistics



### INNOVATION AWARD

- Pets at Home
- Card Factory
- Hermes
- ArrowXL
- Best Food Logistics
- Carousel Logistics
- Gefco
- Christie Lites
- Wincanton

### NEW FACILITY AWARD (UNDER 150,000 SQ FT)

- Formica Group
- Hermes
- Kuehne + Nagel
- The Co-op
- McGinley Logistics

### OPERATIONS LARGE AWARD (MORE THAN 500 EMPLOYEES)

- CEVA Logistics with Rolls-Royce
- Hermes
- Heineken UK
- NHS Supply Chain
- Budweiser Brewing Company

### OPERATIONS SME AWARDS (LESS THAN 500 EMPLOYEES)

- McCulla
- Dynamic Medical Logistics
- Fortec Distribution Network
- Hilti
- James and James Fulfilment
- Murphy & Son
- Barnack Storage & Logistics

### NEW FACILITY AWARD (OVER 150,000 SQ FT)

- Hachette
- Mantra Learning
- Decathlon
- Barnack Storage & Logistics
- UPS
- Aldi

### WELL-BEING INITIATIVE AWARD

- FB Chain
- Decathlon
- Gefco
- Wincanton



### TECHNOLOGY TRANSFORMATION AWARD

- Wincanton with Adidas
- NHS Supply Chain
- Marks & Spencer
- CEVA Logistics with Rolls-Royce
- Pets at Home
- Brakes Group

## TOYOTA

### MATERIAL HANDLING

### SAFETY AWARD

- Wincanton with Adidas
- Nestlé UK
- Fortec Distribution Network
- Clipper Logistics

### WAREHOUSE EFFICIENCY AWARD

- Pets at Home
- Britvic
- Siemens
- Wincanton
- Great Bear
- Card Factory
- Jack Wills

### SPONSORED BY:



### CHARITY PARTNER:





# NEED A SOLUTION THAT'S DESIGNED AROUND YOU?

*We can handle it.®*

Discover the UK's widest range of purpose-built handling equipment on stand **6E215** at **IMHX**. Our unique funding solutions provide you with complete flexibility, delivering new levels of efficiency and cost-savings.



**0800 169 9789**  
[www.impact-handling.com](http://www.impact-handling.com)

**KONECRANES**  
Lift Trucks  
**carer** **Rocla**

**COMBISET** **bulmor** **Ver**  
**Spykstaal** **JLG**

**IMPACT** **CAT**  
Lift Trucks



## ▶ NAGA MUNCHETTY TO HOST IN 2019



Popular television presenter and journalist, **Naga Munchetty**, will announce the winners of this year's Logistics Awards at a gala evening taking place on Thursday 26 September during IMHX 2019.



## ▶ THE VOX



The Vox opened its doors in September 2015. It is situated within the £150 million integrated leisure and entertainment destination, Resorts World Birmingham on the NEC campus – the first destination of its kind in the UK.

The banqueting space at The Vox has been designed to stand out from the crowd and has the 'wow factor.' Its location, teamed with enviable technical facilities

and premium seating, makes this a super-powered venue.

A table at The Logistics Awards includes a sparkling reception, fine food and wine, entertainment and an evening of networking with over 500 industry professionals. Carriages at 1pm.

**To book your table visit**  
[www.logisticsawards.co.uk](http://www.logisticsawards.co.uk)

# GET MORE DONE FASTER



## THE PRODUCTIVE CHOICE

The redesigned 10MSP-S stockpicker boosts productivity. Simultaneously drive and lift. Carry up to 385 kg in one trip. And operate safely with dual-handed controls. The standard maintenance-free AGM battery requires less maintenance to maintain proper water levels. That means fewer service calls and lower total cost of ownership. The machine's lubrication-free mast guide system also reduces scheduled downtime and promotes higher utilization.

Learn more at [www.jlg.com/en-gb/equipment/stock-pickers/driveable-stock-pickers/10msp-s](http://www.jlg.com/en-gb/equipment/stock-pickers/driveable-stock-pickers/10msp-s)



JLG Industries (UK) Limited | Bentley House, Bentley Avenue  
Middleton, Greater Manchester | M24 2GP | [europe@jlg.com](mailto:europe@jlg.com)



# INDIGO SOFTWARE

LOCATED: HALL 19, STAND J80  
& HALL 20, STAND F30

## BOOST WAREHOUSE EFFICIENCY WITH INDIGO WMS

Holding excess inventory can be costly and is becoming more widespread due to future economic uncertainty. When it comes to raw materials and finished goods management, it's no longer a case of 'just in time' but a question of 'just in case'. Here are 5 ways Indigo WMS (Warehouse Management System) will boost your warehouse operations.

**Putaway management and location assignments** - Effective put-away maximises space utilisation and ensures product movements are minimised. Indigo WMS automates this by identifying where to store items based on available spaces, pick frequency and special storage considerations.

**Pick route optimisation and planning** - Travelling absorbs a large part of picking time, so sequencing tasks within an order is crucial for efficiency. Indigo WMS evaluates the day's order pool, assigns tasks to operatives and shows them the fastest routes to reach stock items. Goods are picked more quickly, using minimal resources.

**Shelf life management and stock rotation** - Using Indigo WMS to optimise stock rotation means items with a limited shelf life are picked first to avoid wastage. Indigo WMS simplifies this by reminding operatives of which lots to select first.

**Perpetual inventory (PI) stock counting** - Daily PI or cyclical counting supported by Indigo WMS eliminates the need for monthly or annual stock counts. It is business as usual whilst stock counting is in progress and shrinkage is minimised, because material movements are automatically tracked electronically.

**Traceability management** - Indigo WMS creates reports detailing lot / batch / expiry date information which conform to compliance requirements and enable trend analysis. Users have a full audit trail tracking each element of stock during its entire lifecycle, right down to the source of raw ingredients at the SKU, UPC and lot level.

Visit Indigo's stands at IMHX 2019 where its supply chain experts will be available with practical strategies to make your warehouses as efficient as possible. ■



## IS YOUR WAREHOUSE COSTING YOU MONEY?

WE ASKED WAREHOUSE MANAGERS ABOUT THE ROI THEY HAVE OR WILL RECEIVE FOLLOWING THEIR IMPLEMENTATION OF INDIGO WMS

WE ARE PLEASED TO BRING YOU THESE HANDY SAVINGS STATISTICS

\*Based on factory reconditioned equipment

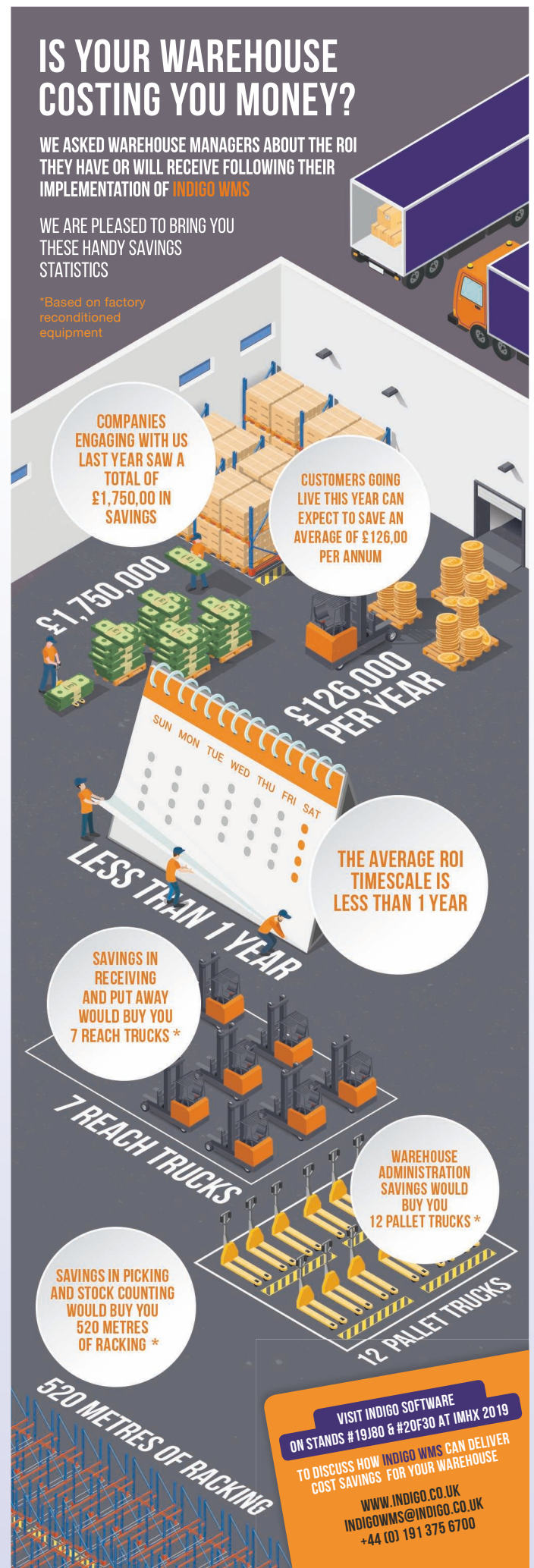

# ► DESIGN4SAFETY AWARDS



This year, IMHX will once again host the **Design4Safety Awards**, organised by the British Industrial Truck Association (BITA).

The aim of the awards is to highlight the importance of product or service design in improving safety standards. By focusing specifically on design, the awards recognise and celebrate innovative thinking – regardless of the type or cost of the product or service.

There are six different categories available which encompass every area of the materials handling industry:

- Industrial Vehicles & Ancillary Products
- Automation & Robotics
- Warehouse Infrastructure
- Racking & Storage
- Technology
- Training & Operations

**Winners will be announced on Thursday 26th September 2019 at The Logistics Awards, being held at The VOX, Birmingham.**

All IMHX exhibitors were invited to enter the Design4Safety Awards.

## CONGRATULATIONS TO THE FOLLOWING FINALISTS!

- Hyster Europe
- Toyota Material Handling
- RTITB
- Storax UK
- Campisa
- Combilift
- PD Industrial
- Elokon
- Crown Lift Trucks
- Garantell
- Konecranes Agilon
- Mentor Training
- Stommpy UK
- Wessex Packaging
- Faraone UK
- Workaround
- Interfit/Trelleborg Wheel Systems
- Lesar UK
- ProGlove

THE LOGISTICS AWARDS

PROGRAMME

@SHOULOGISTICS | LOGAWARDS18

Thursday 26th September

► **BOOK YOUR TABLE**

To book your table for the networking night of the year visit [www.logisticsawards.co.uk](http://www.logisticsawards.co.uk)



**Kubota,  
The  
Answer**

**IMHX™ 2019**

The UK's largest intralogistics event  
24 - 27 September | NEC • Birmingham  
Stand 20D55

**STAGE V**

**V4309**  
4.3-liter 115.7kW

**V5009**  
5-liter 157.3kW

**The New Kubota 09 Series**  
4 cylinder diesel engine

[www.kubota-eu.com](http://www.kubota-eu.com)  
For Earth, For Life  
Kubota  
<https://global.engine.kubota.co.jp/en/>

 **Logistex**  
a sure thing

**experts in warehouse automation**

**Integrated warehouse solutions design & implementation**

Logistex are specialists in storage and retrieval, order forwarding, picking and sortation systems. As an independent company with no manufacturing ties, it integrates products from across the industry without compromise. Combining the freedom to source the most suitable equipment from the market with its own in-house software expertise, Logistex blends the various components into a holistic, integrated system.

**IMHX™ 2019**

The UK's largest logistics event  
24 - 27 September | NEC • Birmingham

Visit Us on  
Stand

**18L110A**



T: +44(0)1536 480 600 | E: [Enquiries@Logistex.com](mailto:Enquiries@Logistex.com) | [www.Logistex.com](http://www.Logistex.com)



# ▶ KNAPP

**LOCATED: HALL 20, STAND D128**

Global warehouse automation provider, KNAPP, will be showcasing its intralogistics solutions on stand D128 in Hall 20. With over 1,700 active installations worldwide, KNAPP designs, delivers and supports automated material handling systems that feature the latest storage, picking and transport technologies, along with leading-edge software. Headquartered in Graz, Austria, the KNAPP group employs more than 4,500 staff across 41 locations worldwide and achieved a net turnover of 954 million euros in the business year 2018-19. Its key industry sectors are retail, e-commerce, fashion, healthcare, food retail and industry.

## HIGH-PERFORMANCE SHUTTLE TECHNOLOGY

Craig Rollason, managing director of KNAPP UK, says: "We are renowned for delivering highly efficient and accurate storage, order picking and dispatch systems. Our OSR Shuttle™ Evo – the latest generation of KNAPP's shuttle storage system – forms the heart of many of our solutions. Developed with our experience from over 25,000 shuttles delivered across 250 shuttle systems worldwide, OSR Shuttle™ Evo is designed for optimum performance in terms of speed, availability, energy efficiency and durability."

## BRAND-NEW ORDER PICKING STATION

Exhibited for the first time in the UK at IMHX will be the company's new Pick-it-Easy Evo workstation, which visitors will be able to interact with in live demonstrations on the KNAPP stand. Pick-it-Easy Evo combines ergonomic design with intuitive operation to enable warehouse staff to work smart, not hard.

A multitude of functions can be performed at the new workstation – from standard processes such as picking, decanting, consolidation and returns handling, to customer-specific operations. In addition, Pick-it-Easy Evo is designed to handle a broad range of goods and load carriers – containers, trays and cartons in various dimensions – with loads of up to 50kg. "Developed to work in synergy with our OSR Shuttle Evo automated storage system," explains Craig Rollason, "the Pick-it-Easy Evo can either have a traditional connection to the store through a pre-zone or it can be connected directly to the OSR Shuttle in order to save space."

## CORE TECHNOLOGIES

A key technology used in many KNAPP retail and e-com solutions is the company's Pocket Sorter, which combines an overhead conveyor system with matrix sortation to arrange



pockets containing picked items into the precise sequence required for dispatch. Other products that will be promoted on the KNAPP stand include its Open Shuttle AGVs, the KNAPP-Store robotic ASRS, A-frame autopickers, the Pick-it-Easy robotic order picking system, intelligent conveyors and the range of garment-handling systems from Dürkopp Fördertechnik, a member of the KNAPP group.

KNAPP's stand at IMHX will present its core technologies, including its redPILOT software and a virtual reality experience. The redPILOT solution is a cloud-based software – developed by redPILOT GmbH, a start-up company within the KNAPP group – designed to optimise warehouse logistics, with all experience gained being used for machine learning. The redPILOT solution helps warehouse operators to use available resources – such as systems, personnel, energy, space and materials – dynamically and intelligently in order to optimise performance in a context of constantly changing factors such as order structure, delivery dates and store optimisations.

As well as touching the physical equipment on the KNAPP stand, visitors will have the opportunity to experience KNAPP's virtual reality warehouse with its Pick-it-Easy Virtual system. "Equipped with VR glasses and joysticks," explains Craig Rollason, "visitors will be able to move around interactively in our virtual warehouse to experience a range of KNAPP automation technologies at first hand. In addition, members of our product development, sales and service teams will be on hand to discuss any potential projects or particular logistics challenges with visitors." ■







© Schukat

**IMHX<sup>TM</sup>**  
**2019**

Visit us on stand  
**20 D128**

# making complexity simple

KNAPP is a leading global supplier of warehouse automation solutions, with over 1700 active systems worldwide. The group's advanced conveying, storage and fulfilment technologies are combined in solutions that feature seamless integration and intelligent software. Successful projects in the UK recently include systems for John Lewis, Boots, M&S, Staples, Clarks, British Gas, Well and Debenhams.

KNAPP UK Ltd  
Unit 60, Monument Business Park  
Warpsgrove Lane, Chalgrove  
Oxfordshire OX44 7RW  
Tel: 01865 965 000 | [sales.uk@knapp.com](mailto:sales.uk@knapp.com)  
[www.knapp.com](http://www.knapp.com)

**KNAPP**



▶ **MANITOU**  
**LOCATED: HALL 20, STAND C140**



Manitou's stand, C140 in Hall 20, will feature four machines from its extensive range of equipment. The new ER16 electric reach truck will take pride of place on the stand. With a rated capacity of 1,600kg, to 8 m, the ER16 is designed for daily work in highly productive, busy, environments. The compact ER16 (1.23m long x 2.2m wide) is designed to work in aisles from 2.6m. The ER16's drive and lift performance delivers efficient order picking and the integrated 'S3 pack' assures safety by automatically monitoring and controlling the machine's drive and lift speeds depending on the mast tilt and position. The ER range comprises of six models with rated capacities from 1,200 to 2,000kg.

A Manitou ME315, 1,500kg lift capacity will also be exhibited. Available with a wide range of masts from 2.7 to 6.5m lift heights the ME315 is powered by a 48V,

460Ah battery. A third electric machine will also be on show in the form of an EP15, 1,500kg lift capacity electric pallet truck.

The final machine to be displayed at IMHX by Manitou is one of its range of diesel powered masted forklifts. The MI25D forklift is designed to handle loads of up to 2,500kg on solid surfaces. Powered by a 35kW Yanmar diesel engine, and with a simple and robust design, the MI25D ensures a quick return on investment, easy maintenance and enhanced longevity. It comes equipped with a duplex mast as standard, with optional masts available with lift heights from 3.3 to 6.5m.

Specialists from Manitou Group and Manitou Finance will be on-hand throughout the 4-day exhibition to advise visitors on the wide product range plus competitive end-user hire purchase and lease options. ■





# THE COMPLETE WAREHOUSE RANGE



To discover our extensive **Warehouse Range** please visit [www.manitou.com](http://www.manitou.com) or contact your local Manitou dealer

## ▶ MECALUX

**LOCATED: HALL 6,  
STAND D210**

Over more than 50 years, Mecalux has built a reputation as one of the leading storage systems companies on the market. It acts as a one-stop provider in the UK, implementing the right mix of product solutions: warehouse management software, automation of warehouses, metal racking and internal conveyor systems. Our design, manufacture and sale of these, and many more top solutions, puts us in a unique position to help businesses grow in the UK.

By working with a technological partner like Mecalux, customers gain a competitive edge – according to the company – with comprehensive solutions and storage designs tailored to their facilities.

“

*The home décor and furniture company Dwell now locates 22,000 pallets of goods in double- and single-depth pallet racking from Mecalux for higher product outflows.*”

### CUSTOMER SUCCESS STORIES

Ongoing customer projects are being launched through our UK office with businesses around the country. For example, Mecalux recently collaborated with the sports retailing giant Decathlon in setting up its picking warehouse, which can now supply product to point of sales and fulfil online orders of its products in the UK. Household name Churchill China has increased productivity by 10% with new pallet racks and expanded its picking space by 40% with Mecalux shelving for picking.

On the other hand, the home décor and furniture company Dwell now locates 22,000 pallets of goods in double- and single-depth pallet racking from Mecalux for higher product outflows. Another example is Hepco Motion a linear motion systems specialist which optimised a new space with speciality cantilever racks custom mounted on Movirack mobile bases. Yamazaki went fully automated and perfectly organised all its parts in an Automated Warehouse for Boxes



run by a stacker crane, modernising its traditional warehouse operations.

### AUTOMATED WAREHOUSES

Automated storage and retrieval solutions run a warehouse's reception, storage and order processing operations for palletised items. The results are an increase in productivity, lower costs and improved speed and safety in your warehouse.

Robust pallet racks are run by Mecalux's top-of-the-line stacker cranes, representing an affordable, simple, low maintenance way to automate a warehouse. The handling equipment reduces errors in stock management and improves safety in moving goods. They adapt to special working conditions such as freezing temperatures (-30° C), extreme humidity or can include special features, such as the possibility of increasing standard working speeds.

The conveyor systems are an ideal addition to the above. Improving the efficiency of processes, they are integral in the receipt, handling and dispatch of pallets. As an extension of an automated warehouse, they connect warehouse areas, ensuring fast delivery of materials and merchandise in-house. Pallet conveyor systems mean high performance, fully automated product manipulation, with a wide range of versatile components for different applications.

### PALLET RACKS AND PICKING SHELVES

Mecalux's high-quality industrial racking for pallet storage is the core of any organised warehouse. Pallet racking can be selective for direct access to each pallet or accumulative for higher storage capacity. Made from certified high-strength steel and a coat of durable

powder mean the structure is rigid, reliable and safe. Rack heights and aisle widths are tailored to the in-warehouse lifting devices, the pallet sizes used and the dimensions of each warehouse. Industrial metal picking shelves are designed to store individual boxes or single products. With the boom of e-commerce and single-unit orders, shelving for picking is the ideal system for goods which are stored and retrieved manually. From shelf variants for hand picking of medium to heavy goods to live storage channels, these shelving systems provide perfect access and turnover. ■

10%

Churchill China  
has increased  
productivity by 10%

## ▶ PALLET SHUTTLE

- Compact powerful technology.
- Deep lane pallet storage (up to 40m).
- Low maintenance, decreased incidents.
- Control tablet runs all functionalities.
- Very cost-effective.
- Get high-speed inputs and outputs of merchandise.
- Built-in safety features are designed to ensure correct operations.
- Scale your system and easily added more shuttles as productivity rises.
- Use any handling equipment to carry the shuttle.
- Eliminate stock-keeping errors.
- Increase the flow of goods in and out of the warehouse.
- Save time in loading and unloading, since operators do not enter the work lanes.



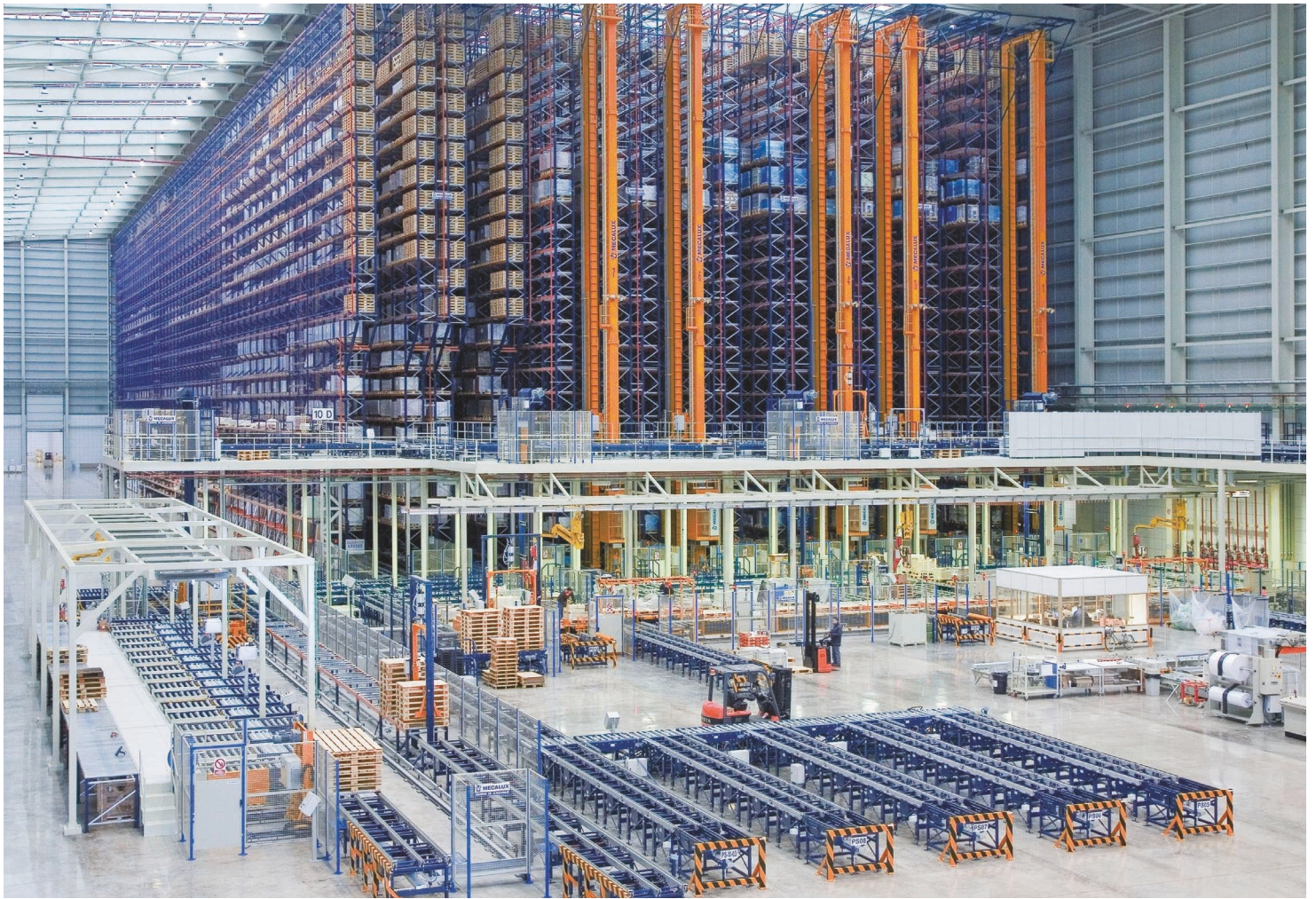

## Do you need an organised warehouse and complete stock control?



**Mecalux offers the best storage solutions to suit your needs**

Pallet racking . Picking shelving  
Automated warehouses for pallets and boxes  
Warehouse Management Software Easy WMS



**Visit us at  
Booth 6D210**

**IMHX<sup>TM</sup> 2019**

The UK's largest intralogistics event  
24 - 27 September | NEC • Birmingham



## ▶ YALE

**LOCATED: HALL 19, STAND K120**



Yale Europe Materials Handling is set to exhibit at intralogistics event IMHX 2019 on 24 – 27 September, alongside its UK distributor Briggs Equipment. Yale will be displaying a range of solutions for logistics and warehousing applications on stand 19K120.

Yale brand manager, Iain Friar, said: "We are excited to return to IMHX, for what promises to be another fascinating showcase of logistics trends, products and services. From robotics to Very Narrow Aisle trucks, pallet trucks to alternative power options, we are looking forward to sharing the latest Yale solutions for boosting productivity alongside our exclusive UK distributor, Briggs Equipment."

Yale will display its robotic counterbalance stacker for the first time in the UK since its launch last year.

Yale robotic trucks, driven by Balyo technology, offer a cost-effective

solution for applications looking to introduce autonomous technology and reap the benefits of increased uptime and productivity, without the costs associated with installing and maintaining a dedicated physical infrastructure.

There's no need to bury wires in the floor or mount reflectors on walls: Yale robotic trucks use existing structural features to generate their own map, enabling them to self-locate and navigate in real-time. Yale currently offers customers a choice of three robotic trucks, all with dual-mode capability, allowing them to operate manually or autonomously with the touch of a button.

### ALTERNATIVE POWER SOLUTIONS

Alternative power solutions are a rapidly growing aspect of the materials handling industry and Yale will be showcasing a lithium-ion powered version of its award-winning MP20 pedestrian pallet truck at IMHX.

The MP20 pedestrian pallet truck will also be fitted with the precision control tiller head, offering greater control for customers operating in congested spaces without compromising on ergonomics.

Industry experts will be on hand to discuss the challenges and benefits of individual power solutions, helping visitors discover the most appropriate energy sources for their operation.

Visitors with very narrow aisles need look no further than the Yale MTC15 Very Narrow Aisle truck. Capable of lifting to 17m, Yale VNA trucks allow warehouse managers to increase their storage density and ensure all available usable space is being maximised.

From their elevated position, the operator has excellent visibility of the pallet at all times, as well as the ability to perform picking when required. While the speed to weight feature calculates the fastest possible speed for the truck based on the height of the cabin and the weight of the load. ■

## MEZZANINE<sup>®</sup>

### International Limited

A MITEK<sup>®</sup> / BERKSHIRE HATHAWAY COMPANY

## The UK's premier mezzanine company

### Partnership. Integrity. Innovation.

Mezzanine International Ltd is the UK's Number 1 mezzanine floor supplier\* delivering structural steelwork across Europe and the rest of the world.

We specialise in the design, manufacture and installation of integrated, future-proofed mezzanine flooring systems. Our technical expertise helps our clients to maximise productivity and space, whilst saving money and increasing profitability.

\*PLIMSOLL 2015, 2016 & 2017

**Mezzanine International**  
11 Tower Hill, West Malling  
ME19 4UY, United Kingdom

+44 (0)1732 849 900  
[www.mezzanine.co.uk](http://www.mezzanine.co.uk)

We are part of the MiTek<sup>®</sup> family,  
working closely with Cubic Designs;  
MiTek's<sup>®</sup> North American mezzanine supplier.

**MiTek<sup>®</sup>**

**Cubic Designs**  
MEZZANINE SYSTEMS  
A MITEK / BERKSHIRE HATHAWAY COMPANY

Visit us at IMHX  
Hall 6  
Stand C186



# ▶ NORD GEAR

LOCATED: HALL 18, STAND N70

With more than 3,900 employees, Nord Drivesystems has been developing, producing and selling drive technology for over 50 years, and is one of the leading global full-service providers in the industry. In addition to standard drives, NORD delivers application-specific concepts and solutions for special requirements such as energy-saving drives or explosion-protected systems. In the 2018 financial year annual sales amounted to €700m.

Nord now has subsidiaries and sales partners in 89 countries worldwide. The extensive sales and service network guarantees optimal availability, enabling short delivery times and customer-oriented service. The company produces a very diverse range of drives for torques from 10 Nm up to over 250 kNm, provides electric motors in the power range of 0.12 kW to 1,000 kW, and manufactures frequency inverters with the required power electronics of up to 160 kW. Inverter solutions are available for conventional control cabinet

installations as well as for decentralised, fully-integrated drive units.

At the IMHX exhibition the company is showing costs savings through reduction of geared motor versions and Industry 4.0 connectivity.

For material handling equipment it has specifically developed the Logidrive range which is an energy efficient, maintenance-friendly and standardised solution for intralogistics and airport applications.

The solution consists of an efficient gearbox, IE4 permanent magnet synchronous motor and a decentralised variable frequency drive.

Gear unit standardisation minimises the number of geared motor versions required for the task, achieving considerable savings for spare part stocks. The variable frequency drive and IE4 motor support large speed ranges through a single gearbox and motor



combination. Installation of the Nordac Link field distributor close to the motor, in combination with the decentralised drive with plug and play technology, make installation and maintenance a breeze.

Fieldbus connectivity provides remote diagnostics and monitoring by using all industry standard bus systems with various conditioning monitoring options, either remote or local.

Efficient operation at partial load and low speeds, variant reduction and fieldbus connectivity make the Logidrive an ideal solution for high-volume intralogistics systems. ■

## Ultra high efficiency IE4 drives with Permanent Magnet Motors



### LogiDrive

The ultimate drive package when it comes to efficiency and flexibility.

The highest efficiency IE4 PM motors combined with either right angle, inline or parallel gearboxes that are at minimum 96% efficient guarantee the lowest running costs.

Flexibility through design, with inverter drives that are configured to have all options inside removing the need for external gateways or controllers.



EtherCAT

EtherNet/IP

ETHERNET POWERLINK



RELIABLE

VERSATILE

GLOBAL

NORD Gear Limited  
 T: +44 1235 534404  
 E: GB-sales@nord.com  
 W: www.nord.com

# ▶ ONES TO WATCH

We continue previewing some of the key names to look out for at this year's IMHX, 24-27 September, NEC Birmingham.

## FRONIUS UK

Fronius UK will be back with its innovative Ri charging process and showing visitors how using their technology and battery chargers can save money for forklift fleet owners.

Fronius welcomes warehouse and logistics managers and forklift fleet owners to come and discuss the savings potential when switching their existing forklift battery chargers to intelligent, Fronius Selectiva battery chargers with the "Ri" charging process unique to Fronius.

Its offerings range from the sale of single battery chargers to total system solutions including multiple charging modules, battery changing systems and complete charging rooms.

Fronius has developed an intelligent solution to dramatically improve the utilisation of traction batteries. A control unit connected to an LED strip on each charger intuitively leads the user to the battery that has been fully charged for the longest and is therefore the coolest, thus increasing the service life of the battery whilst reducing the total operating costs and optimising the performance and availability of your forklift truck fleet at the same time. ■



Located: Hall 18, Stand M60

## NARROW AISLE

IMHX 2019 will see the official launch Narrow Aisle's new Flexi ACiON and Flexi LiTHiON VNA lift truck ranges.

With all drive, hydraulic and power-steering functions controlled digitally, the trucks in the Flexi AC iON (lead acid battery-powered) and Flexi LiTHiON (lithium-ion battery-powered) collections are described as a 'tour de force' in articulated lift truck drivability and reliability.

The introduction of digitally controlled motors for all key functions delivers a more integrated truck performance and results in greater reliability, higher productivity and significantly reduced operating and maintenance costs.

Full digital control means that all models are ultra energy efficient: every time the truck's mast is raised or lowered, as well as during forward and reverse travel and when the steering wheel is moved, regenerative energy is produced and feeds back to the battery to maximise the time that the truck can perform between battery changes or charges. ■



Located: Hall 20, Stand E120

## AR RACKING

Spanish firm AR Racking, a leading company in the international storage systems market, will be present at IMHX, the largest event within the logistics and supply chain industries in the UK.

The company will display its wide range of solutions and services ranging from the design and planning of storage systems to its installation and implementation. AR guides all phases of the project to increase the competitiveness of the client's facilities and equipment through effective solutions with high quality standards.

AR Racking is part of the Arania Group, an industrial group of companies of great experience and scope, with a multi-sectoral activity based on the transformation of steel that dates back more than 75 years. AR Racking provides the market with a wide range of solutions with high certified quality standards. It has a fully automated production plant and its own R&D&I technology centre. ■

## PYROBAN

At IMHX 2019, Pyroban will continue its celebrations marking 50 years since the start of Project Pyroban.

Pyroban experts will be discussing a range of explosion protection solutions that help manage the risk of ignition found in materials handling equipment.

The project began in 1969 in the UK to provide explosion protection for industry above ground, giving birth to Zone 2 areas in conjunction with the (then) UK government HSE.

Visitors will see working examples of Pyroban equipment including system6000

for Zone 2 areas, and Gascheka used in safe areas. Pyroban experts will also be advising users and equipment suppliers about training, service support and annual auditing of explosion proof lift trucks and the legal requirements.

Pyroban equipment is fully certified to the European ATEX 2014/34/EU and other international standards and experts will be available to answer questions about explosion protection requirements at all levels. ■

Located: Hall 20, Stand E25



Located: Hall 18, Stand L100





# We design. So you can deliver.

At RCR we have the products and expertise to keep your warehouse floor running smoothly. Because when deadlines are tight, you can't let the floor slow you down.

From design to operation, we've thought of everything. For new builds, our concrete engineers help achieve superb flatness. We have impact-free joints, so MHE can glide across in any direction, fast. Our specialist coatings withstand scraping, chemicals, loads and impact. Problems with your existing floor? Our professional repair team will fix them, once and for all. And our optimisation service helps your floor and MHE work in perfect harmony. You could say we take warehouse floors to another level.

[www.rcrindustrialflooring.com](http://www.rcrindustrialflooring.com)

## IMHX<sup>TM</sup> 2019

The UK's largest logistics event  
24-27 September  
Stand 20F35



Permaban Wave impact-free armoured joint



Permaneo joint repairs

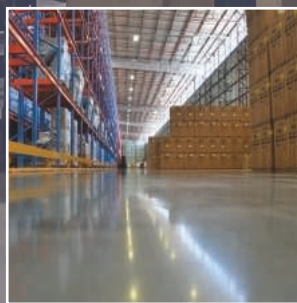

Monofloor design and consultancy



Floor Dynamics HD mapping and analysis

## Leaders of the flat world





# ▶ SPACIOTEMPO

LOCATED: HALL 20, STAND C105

The UK's leading supplier of semi-permanent structures aims to attract the attention of the exhibition's 20,000-plus visitors by installing a Neivalu within the main hall at the NEC.

The company's skilled Operations Team will arrive on site just days before the event to erect the structure, measuring a 10m x 5m with a 3m integrated canopy, demonstrating the speed and ease in which the facilities can be up, running and benefiting your business.

Dedicated members from across the Spaciotempo team will be bringing their expertise to the stand, ready and waiting to provide information and guidance on the company's product range.

#### OXYGEN BUILDING

Divisional director John Drake says he was confident the structure's high-quality, cost effective nature would impress attendees.

He adds: "At the last IMHX, we unveiled

our eye-catching Oxygen building – which was extremely well received – so we decided to once again let our product do the talking by installing our most popular design – the Neivalu.

"It's anodised aluminium frame with galvanized steel fixings guarantee inherent strength and solidity, making it the perfect fit for any environment while its modular design means it is ideal for when a business experiences a change in customer demand.

"Our expert teams work closely with clients throughout the entire process to tailor the structure to their exact specification, whether that is lighting, doors, windows or roof coverings and on top of all of that, the frames come with a 10-year guarantee as standard."

#### BREXIT UNCERTAINTY

Spaciotempo's temporary structures have never been more relevant to businesses wanting to expand but who are

uncertain about investing large amounts of capital in a permanent building or who cannot afford soaring rent prices sparked by the lack of warehousing space.

Drake adds: "In the midst of Brexit and following years of economic uncertainty, businesses are still understandably reluctant to commit to long-term investments which is where our semi-permanent structures come to the fore.

"We have helped countless businesses across the UK and Ireland to successfully expand at around one third of the cost and in far less time when compared to constructing a permanent building. No other option can give you the flexibility, scalability and affordability of Spaciotempo's temporary buildings.

"If you want to cut costs without cutting corners, we guarantee to find the perfect solution for your business. Come over and have a chat to us at IMHX and see for yourselves how and why our bespoke buildings truly do stand out in a crowd." ■



**IMHX<sup>TM</sup> 2019**

The UK's largest intralogistics event  
24 - 27 September | NEC • Birmingham



Visit Spaciotempo  
on stand **20C105**

and see one of our impressive  
semi-permanent buildings for yourself.

Our team of experts will be more than happy to explain how Spaciotempo can help your business to save time, save money and grow.

To find out more, or to pre-book an  
appointment with the team, call us now on:

**01889 569569**

**sales@spaciotempo.co.uk**

[www.spaciotempo.co.uk](http://www.spaciotempo.co.uk)





# End-to-End Total Logistics Solutions

We're experts in delivering warehouse management and transport management software, available as stand-alone or complete integrated solutions.

## What makes us different?

You can implement our software as individual modules or as a unified solution. Our software is highly intuitive, feature-rich and drives efficiency in your business. We've been developing solutions for over 30 years and we're trusted by companies all over the world to look after their warehouse and transport operations.

**Software from Sanderson powers your entire supply chain.**

*Meet our team at the IMHX show on 24th - 27th September at NEC, Birmingham to discover more about integrated solutions.*

Hall 19  
Stand 105  
**IMHX 2019**  
The UK's largest logistics event



[www.sanderson.com](http://www.sanderson.com) | [info@sanderson.com](mailto:info@sanderson.com) | 0121 728 8000

 **SANDERSON**

## Maximise your storage space



## Minimise your shipping costs

Get accurate dimensions and weights with CubiScan, the world's leading DWS

Visit our website [www.exds.co.uk](http://www.exds.co.uk) or call us on +44(0)1908 648588 to find out more

 **EXDS**  
EXCELLENT DIMENSIONING SYSTEMS

# UNICARRIERS

**LOCATED: HALL 6,  
STAND A180**



The international forklift truck manufacturer UniCarriers is in search of the most talented forklift operator attending this year's International Materials Handling Exhibition (IMHX) in Birmingham. Together with Talent in Logistics, UniCarriers will host the first ever Forklift Operator Challenge at the exhibition. Entrants will have the opportunity to prove their skill by operating UniCarriers' Award winning electric counterbalance truck TX3.

For this year's IMHX, UniCarriers partner up with Talent in Logistics to honour adept fork lift truck operators. By operating a UniCarriers TX3 counterbalance truck, participants will be able to demonstrate their level of skill and accuracy. "I am absolutely thrilled to be working with UniCarriers at IMHX this year," said Ruth Edwards, business manager at Talent in Logistics. "We have worked together for some time now on our forklift operator competitions and so it seemed only right to partner once again with an organisation that is passionate about recognising the people that operate this great machinery.

It is fantastic to be bringing this live challenge to the 2019 event giving anyone with a valid counterbalance qualification the opportunity to get involved."

## TX3 ELECTRIC

Chris Bates, sales director at UniCarriers UK, comments: "The Talent in Logistics team always creates visually intriguing driver challenges. Our event at IMHX will not only test the competitors' skills from the very start but will also provide the audience with a vibrant spectacle." Before the challenge, UniCarriers will familiarise each entrant with the truck.

The TX3 is UniCarriers' award winning electric counterbalance truck – the Red Dot Design Award in 2018 was just recently followed by the IFOY Award 2019. Competitors at the IMHX event will be able to enjoy the truck's ergonomically designed cab with an optimal all-round visibility. The Forklift Operator Challenge will take place at the Talent in Logistics stand 6B190 but entrants will need to register first at the UniCarriers stand. Participants must be a qualified counterbalance lift truck operator and provide proof of that on-site. ■

Some steps claim to conform to standards  
**our steps have it stamped on them.**

Still the only mobile steps to have achieved the British Standard Kitemark.

**IMHX<sup>TM</sup> 2019**  
The UK's largest logistics event  
24 - 27 September | NEC • Birmingham

For a demonstration of the British Standard Mobile Step Range please visit us at stand no. 19J130 at IMHX 2019. To contact Redhill Manufacturing please call +44 (0)1527 529002 or visit [www.redhillmanufacturing.co.uk](http://www.redhillmanufacturing.co.uk)



**Redhill**



# ▶ SSI SCHAEFER

LOCATED: HALL 19, STAND G20

Powered by supercapacitors, SSI Schaefer's innovative single-level SSI Flexi Shuttle system can handle a variety of stored goods with a capacity of up to 50kg, as a result of its adjustable-width load handling device. The unique feature of this system is the dynamically adaptable storage location sizes according to the dimensions of the stored goods.

The single-level shuttle is designed for use in highly dynamic automated miniload systems with a wide variety of stored goods. It combines the technology of the SSI Schaefer shuttle portfolio with the broad industry knowhow of SSI Schaefer's intralogistics experts and stands out due to its high level of flexibility over the entire product life cycle.

With the SSI Flexi Shuttle, SSI Schaefer is not only offering an innovative solution, but also a modular concept, which

combines shuttles, lifts and a racking system. It allows the creation of bespoke systems with outstanding use of space.

The system is suitable for single, double and multiple-deep storage with variable height and width partitions up to an aisle length of 150m and a height of up to 30m. Having a comprehensive system that can efficiently store a broad spectrum of loading units and

dimensions in a space-optimised manner is a significant advantage. The ability to handle a range of loading units with dimensions of up to 860 x 680mm is guaranteed by a universal load handling device, which is adjustable in width. Within one racking system it is possible to efficiently and safely store a mixture of cubic and conical bins (totes), cartons and trays weighing up to 50kg.

The fully automated shuttle plays an important part not only in sustainably increasing energy efficiency, but also in optimising costs throughout the entire logistics chain when analysing the total cost of ownership (TCO). The integration of supercapacitors as an energy source guarantees maximum performance density at the highest levels of technical performance. They also function as temporary energy-storage units whilst energy is recovered during braking processes. ■

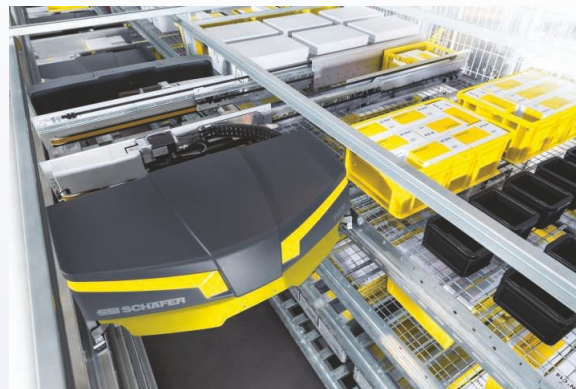

## TAKING STORAGE TO A NEW DIMENSION

Assimilate • Evaluate • Design • Deliver • Support

We understand your business

[www.ssi-schaefer.com](http://www.ssi-schaefer.com)



**SSI SCHAEFER**

## ▶ TVH

**LOCATED: HALL 20, STAND E125**



TVH is a global, all-round supplier of quality parts and accessories for material handling, industrial vehicles and agricultural equipment. With 78 branches worldwide, more than 42 million known references, over 775,000 different stock items and no less than 315,700sq m of warehousing, this company strives to supply you with the right part at the right price as quickly as possible.

Thanks to the extensive stock in the Coventry-based main warehouse and the development of a brand-new warehouse in Kidderminster, TVH UK claim to guarantee fast delivery to all of its customers. The dedicated UK sales

office has personnel trained to process orders via telephone, fax, e-mail, online and face-to-face at the sales counter. The technical staff are always happy to assist with parts indication. All of this is designed to provide a speedy and efficient service.

There will be three TVH booths at IMHX 2019, two of which will display specialised products. The third one will be dedicated to the launch of the new TVH Academy training course calendar.

### DISCOVER TVH AND ENERGIPLUS

In hall 20, stand E125, where the TVH sales staff is happy to reveal

to you all that TVH has to offer.

For example, Energetic Plus specialist Adrian Barker will give a live demonstration of the Energetic Plus Battery Regenerator, the ultimate solution to extend the life of your equipment's traction batteries. Did you know that 80% of the batteries breaking down and losing capacity are sulphated and can be restored if only with the right equipment? The Battery Regenerator successfully removes sulphation thanks to an electrical high-frequency pulsation process. This process restores the battery capacity, giving you the ability to reuse old and sulphated batteries. You can also use the regenerator for annual maintenance to considerably prolong the lifespan of your batteries.

On top of that, the staff will happily explain the progress of their new warehouse in Kidderminster, which should be fully operational in early 2020. In order to guarantee long-term support of its customers on the UK market, TVH has purchased the extra warehouse right in the centre of the UK. The Kidderminster warehouse currently measures 130,000sq ft with a possibility to extend to 185,000sq ft in the future. The extra warehouse will offer TVH's customers later cut-off times for order placing.

### CAM ATTACHMENTS

The second booth, stand E193 in hall 6, is completely dedicated to TVH's privately owned label CAM attachments. This brand originated in Italy and represents an extended range of high-quality attachments for forklifts, telehandlers, tractors and skid-steer loaders. These attachments are used in different types of sectors such as logistics, transport and construction, and are the ideal tool for lifting, hoisting, tilting and shifting different loads depending on the need. CAM attachments has two production plants: one is based in Italy and the other is based in China. Consequently, TVH is able to ship the attachments all over the world. Not only does CAM attachments have local stock in Coventry, it can also offer after-sales service, rental service, second-hand and reconditioned services. You can discover the double pallet handler, rotator, fork positioner and carton clamp on the stand.

### NEW TRAINING COURSE SCHEDULE

On the third booth, stand B212 in Hall 6, TVH Academy will be featuring its new training course calendar. After establishing its own training centre in Waregem (Belgium) in 2008, TVH partnered up with F-TEC in September 2016 and IPAF to offer an equally wide range of professional, high-quality training courses in the UK. ■





# TVH<sup>®</sup>

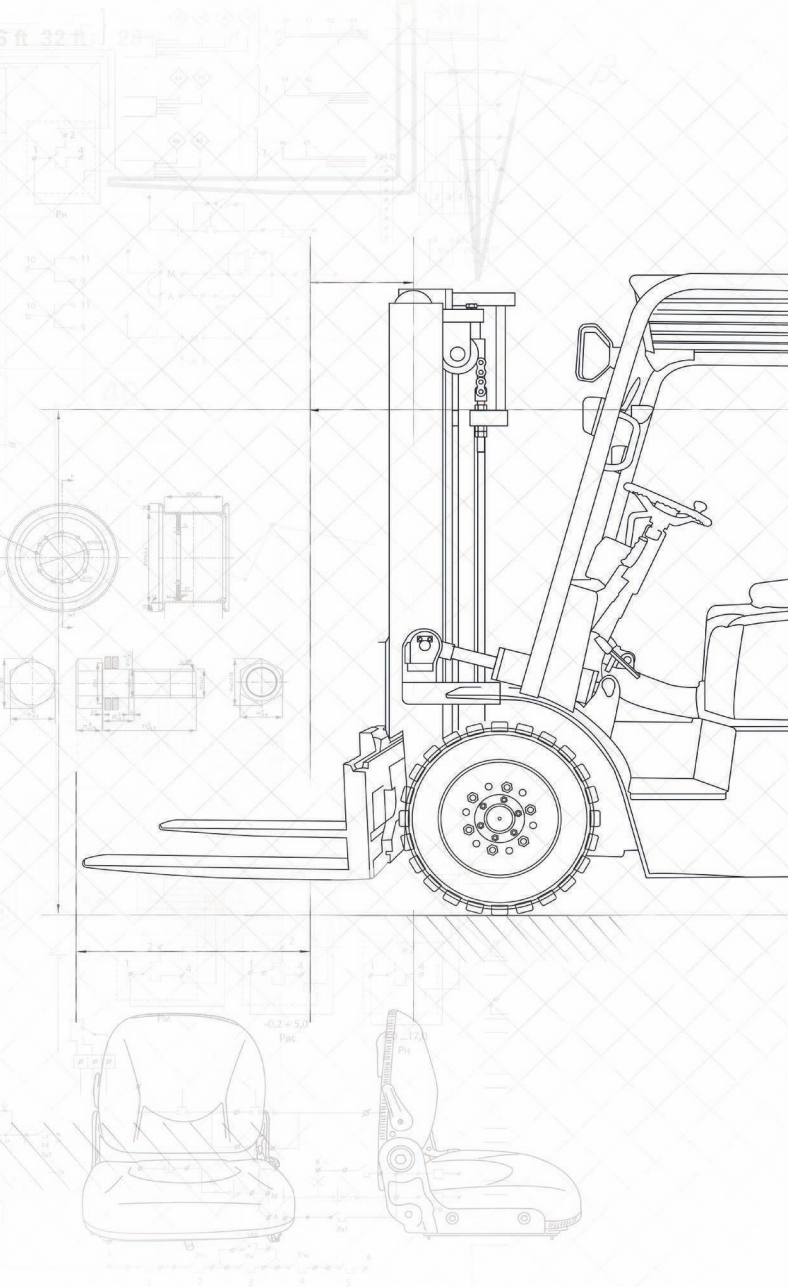

VISIT TVH @  
STAND  
20E125

# PARTS & MORE

Thanks to a stock of over 750 000 references and a database with 37 000 000 known references, you are sure that your **forklift** remains in good shape and is operational at all times. **All makes, guaranteed quality.** Thanks to the extensive stock and our specialised sales advisors, you receive the delivery within **24/48 hours**. Our webshop, online search tools, catalogues, movies and website give you complete access in obtaining information 24/7.

For our complete range, please go to [www.tvh.com](http://www.tvh.com)



TVH PARTS NV  
Brabantstraat 15 · 8790 Waregem · Belgium  
T +32 56 43 42 11 · F +32 56 43 44 88 · info@tvh.com · www.tvh.com

Celebrating  
50 years of TVH



# ▶ WHITTAN

**LOCATED: HALL 20, STAND C100**

Whittan is the UK's largest steel storage product manufacturer in the UK. Through its respected brands: Link51, Apex, Polypal and Probe Whittan is a leading supplier of storage systems across the UK and continental Europe. Whittan has worked with a veritable who's who of names in retail, manufacturing, transport, property, construction, local and national government, and professional services. Employing more than 1,000 men and women, the group's factories process a combined total of over 1,000 tonnes of steel each week. Group factories are focused on manufacturing pallet racking, shelving, cupboards, lockers and plastic containers.

The overall goal is to design, develop and manufacture storage systems for warehouses, manufacturing plants, commercial and industrial locations for a wide variety of sectors. With sectors requiring tailored solutions this means that we design and install manual and automated solutions for warehousing, including conveying, picking and sorting. Whittan also provides front of house and back of house solutions for retailers, archiving solutions for museums, lockers walls for educational establishments, small parts storage for automotive and mobile shelving for commercial offices.

## LINK51 AND APEX

Whittan's stand at IMHX will particularly focus on its two leading warehouse brands, Link51 and Apex. Being part of Whittan allows Link51 and Apex to assimilate their design, manufacturing and installation knowledge, maximising synergies and efficiencies to deliver better customer service.

The company will be showcasing its expertise in implementing innovative storage solutions from 3PL warehouses to complex omni-channel fulfilment centres. Each company has extensive proven experience in delivering scalable solutions, incorporating core Whittan storage products along with dynamic storage, garment hanging and conveyor systems, delivering added value, savings and ROI for customers. From a single shelving bay to dynamic pallet racking, from multi-tier pallet racking or shelving to staff lockers, Whittan has the products to fulfil operator needs.

Maintaining in-house manufacturing ensures its customers benefit from extensive experience in steel forming and fabrication techniques, creating custom-designed storage solutions using standard or 'bespoke' components. European located manufacturing sites ensure ease of supply along with minimal carbon footprint for customers, and operates quality systems in accordance with the latest ISO standards.

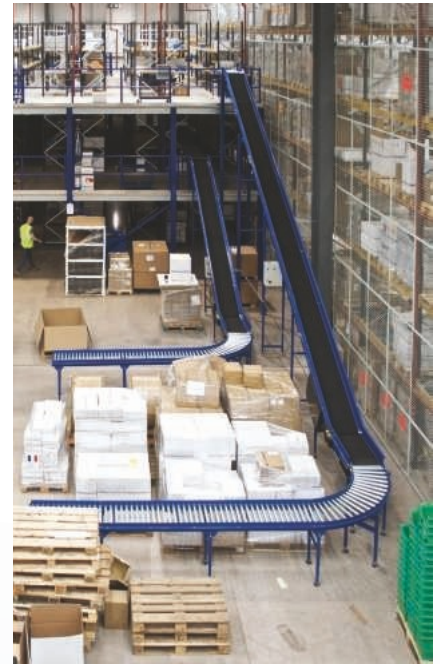

## DESIGN INFLUENCE

Project management and installation of any job is absolutely key. In addition to structural engineers and solutions design experts, both Link51 and Apex have people who have direct experience in large logistics operations and understand how specific points of any design influence the overall flow and efficiency of the operation itself. How to utilise the cube to create the maximum storage space, minimising the distances that product travels and the efficiencies that can be achieved from layouts that drive higher pick rates and greater pick accuracy, Whittan understands the importance of using the most appropriate storage equipment, irrespective of size, complexity or location of the installation.

From the initial briefing and site survey to detailed design proposals, manufacturing, installation and final commissioning, the storage experts take project planning seriously, so you know you're in good hands.

Whittan will also be presenting our bespoke design and specification software, Design 360. This unique system allows customer requirements to be quickly and easily translated into workable designs, utilising Whittan's full portfolio of storage products along with a wide range of dynamic storage equipment.

Whittan will have senior members of our team on call throughout the show to illustrate the pedigree of the group and the depth of products and solutions that the company is able to offer. ■







# Our name carries more weight than you think



**IMHX**<sup>TM</sup> 2019  
The UK's largest logistics event  
24 - 27 September | NEC • Birmingham

Whittan is the UK's largest steel storage product manufacturer, processing over 1000 tonnes of steel each week. We manufacture pallet racking, shelving, cupboards and lockers.

Our respected brands: Link51, Apex, Polypal and Probe, are key in delivering storage solutions throughout the UK and Europe.

We combine expertise in design, manufacturing, and installation, in order to provide the ultimate storage solutions. Our products are UK manufactured, providing efficient warehouse distribution and quality control.

Our business is to deliver optimum storage solutions, to market leading brands in a wide range of sectors.

Our stand at the IMHX, will focus on our two leading warehouse brands, Apex and Link51. Each company has extensive proven experience in delivering scalable solutions, incorporating core Whittan storage products, along with dynamic storage and conveyor systems; delivering added value, savings and ROI for customers.

Senior members of our team are on call throughout IMHX 2019. You may simply be looking to explore some ideas, or have a clear understanding of exactly what you are looking for, so why not meet us for a free, no obligation meeting on stand 20C100.

**APEX** **LINK51**



**CFTS**  
**LOCATED: HALL 6,**  
**STAND F212**

Specialists will be on hand to offer free advice and guidance on the benefits of a comprehensive Thorough Examination.

CFTS — the body behind a UK national standard for the Thorough Examination of lift trucks — will be exhibiting at IMHX 2019 from the 24–27 September.

Despite being a legal necessity, not all lift truck inspections are the same. Technical managers Matthew Kennedy and Adrian White will be at its stand ready to meet visitors, answer questions and explain the essentials behind Thorough Examinations.

Throughout IMHX, visitors to the CFTS stand will also be able to enter a daily competition to win prizes.

**THOROUGH EXAMINATIONS**

“IMHX will be a great opportunity to talk face-to-face with forklift owners and operators about how Thorough Examinations are essential for complying with the law,”

said Kennedy, technical manager for the South in the UK. “A CFTS Thorough Examination checks both the lifting components in alignment with LOLER, as well as critical components such as brakes and steering, covered under PUWER.

“If you’re not sure whether your trucks are compliant, stop by our stand and chat to us. You don’t want to risk anything happening to your staff or your business if your equipment isn’t being checked in its entirety.”

Forklift owners can easily find a Thorough Examination provider no matter what their location, as CFTS has a network of over 500 accredited companies throughout the UK.

Membership continues to grow as more companies expand their engineering services.

“There are lots of benefits to becoming a CFTS member,” said White, technical manager for the North in the UK. “It gives your customers peace of mind that their Thorough Examinations are being conducted by experienced engineers that abide by a strict code of practice. You can also display the unique CFTS mark of certification which shows customers that their truck has been deemed compliant with all necessary legislation.

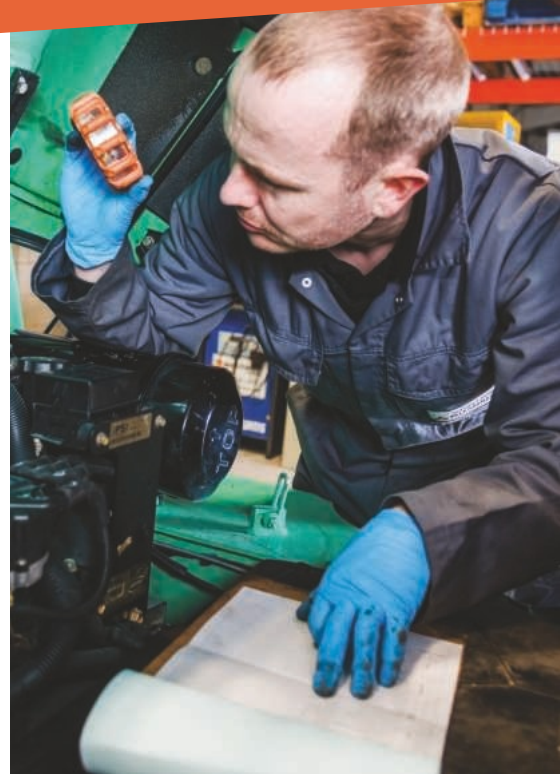

“If you’re considering joining the scheme, then you should definitely pop in to our stand at IMHX. We’ll be able to answer any questions and explain the application process. Plus, if you enter our daily prize draw, you might even win something just for stopping by.” ■

**CoGRI GROUP**

## Optimise Your Warehouse Floor Performance

Floor quality has a significant impact on the efficiency of warehouses and distribution centres. Whatever your warehouse flooring requirements, CoGri has the expertise and experience to provide a professional and practical solution every time.

Established for over 20 years, we are able to provide complete floor solutions from design to construction and upgrading of warehouse and industrial concrete floors.

**FACE CONSULTANTS LTD**  
Global Flooring Consultants

**Superflat High Tolerance Floor Technology**

- Superior floor testing technology
- Design
- Consultancy
- Floor flatness surveying & testing including; abrasion resistance testing, and slip/skid resistance testing
- QA / on-site training
- Bespoke surveys

**CONCRETE GRINDING LTD**  
Global Flooring Solutions

**Specialists in Superflat Floor Grinding**

- Aisles in new and existing floors upgraded to any international flatness standards
- Total grinding flexibility to suit all VNA forklift trucks
- Manual floor grinding
- Superflat floor grinding with the patented Laser Grinder®
- Ultraflat floor grinding with the Laser Grinder® XPT
- Bespoke tolerance grinding
- Minimum interference to operational warehouse environment
- Wire guidance installation

**CG FLOORING SYSTEMS LTD**  
Specialists in Industrial Flooring

**Specialists in Warehouse/Industrial Floor Refurbishments**

- Rapid-set floor screed systems
- Floor coating systems
- Floor surface preparation
- Floor joint repairs and stabilising
- Re-surfacing of worn out floors
- General floor surface grinding
- Floor repair & maintenance products

**For All Your Flooring Needs contact the CoGri Group**  
**+44 (0) 1484 600080**

**CoGri Group**  
 Dene House  
 North Road  
 Kirkburton  
 Huddersfield  
 United Kingdom  
 HD8 0RW

**www.cogrigrp.com**

**CoGRI GROUP**  
 Tel: +44 (0)1484 600080  
 Fax: +44 (0)1484 600095  
 Email: info@cogrigrp.com  
 Website: www.cogrigrp.com



# ZERO MAINTENANCE

The Flexi LiTHiON range is clean, quiet, powerful efficient and easy to drive, says **Narrow Aisle**.

**Narrow Aisle** launched the Flexi LiTHiON range of lithium powered articulated reach trucks at CEMAT in spring 2018 and the lithium product range is becoming a popular choice for a number of specific customer groups.

The fully integrated Flexi lithium-ion system requires zero maintenance and delivers extended multi-shift availability – making models in the collection the ideal energy solution for modern order fulfillment operations, temperature-controlled stores, chemical stores and automotive manufacturing facilities.

Truck availability is optimised thanks to the lithium battery's short recharge cycle: the Flexi LiTHiON battery can be fully charged within one or two hours, even if the battery is fully discharged, which enables the battery topping-up process to be carried out at the most convenient opportunity, such as when the operator is taking a break during his or her shift.

Furthermore, water topping-up is not required, which means that the type of health and safety issues that can arise if liquids are spilt during the traditional lead-acid battery charging process, are eliminated.

With all drive, hydraulic and power-steering functions digitally controlled and integrated with the battery's advanced software systems, the Flexi LiTHiON is able to perform at full power throughout a typical shift with no drop off in performance levels. This ability to distribute consistent power levels, means maximum efficiency is achieved even during the busiest multi-shift operation.

## BATTERY STATUS

The trucks require no battery maintenance – the truck monitors the battery function constantly and reports the battery status in real time – and the combination of fully integrated digital motors and lithium-ion power is so effective when it comes to eliminating wasted power that truck availability is typically increased by 25% every day.

Models in the range can operate safely and efficiently in aisles as narrow as 1.6m wide and can lift loads weighing up to 2.5kg

and to heights of 14m. Like all models in the Flexi range, they feature the easy to drive True Radius technology that allows the truck's mast to rotate through 220 degrees smoothly. True Radius functionality makes Flexis particularly straightforward to operate and has been proved to significantly reduce rack or product damage within any reach truck-serviced warehouse.

Operational efficiency is further enhanced by the low noise output: the trucks are some 30% quieter than, for example, models of the same type powered by LP Gas or with PTO steering.

In fact, John Maguire, managing director of Narrow Aisle, believes that many users of LP Gas-powered handling equipment in warehousing will switch to machines that run on lithium-ion batteries, as the ideal way of reducing running costs, exhaust emissions and operational noise levels.

He says: "LP Gas is costly and linked to global oil prices, and from an operational point of view, the time taken to change or fill each gas bottle means that truck downtime can be a problem for some high utilisation customers. If a bulk tank can be justified then storage of multiple bottles can be avoided. "In addition, the control systems and catalytic converters required to reduce the risk of carbon monoxide emission from LPG engines add significantly to a truck's operating costs, so it's easy to see why many people are talking about lithium-ion powered trucks as a cost-effective alternative to LPG machines."

John adds: "The range is clean, quiet, powerful efficient and easy to drive and will prove a highly popular product with third party logistics service suppliers and own-account warehouse operators looking to achieve maximum supply chain efficiency." ■

19%

A diverse workplace  
makes 19% higher  
revenue

“  
The trucks are some 30%  
quieter than, for example,  
models of the same type  
powered by LP Gas or  
with PTO steering.”

# NEW DIRECTIONS

It's been a busy couple of years at **Translift**. The company discusses its plans moving forward.

In July 2017 Translift was acquired by a combination of the existing key management, including sales director Paul Berrow and Jasper Equity, a Birmingham Private Equity Company.

After the combined team took a fresh look at the business and their vision for the future, Paul Berrow took over as managing director last October. Since then the company has been moving in some new directions.

For over 50 years, Translift has been waging a war on wasted storage space with the continual development and introduction of products and solutions. Each product or service has been brought to market by listening to the needs of customers and today is no different, according to Paul. "It certainly has been an interesting couple of years, but it's onwards and upwards at Translift," commented Paul. "Jasper Equity have been particularly supportive of our efforts, as have Landoll, who we have had a relationship with going way back to the days of Freddie Brown. We've also had some great support from our customers, but it was obvious talking to them that we needed to make investment in key areas such as service and parts. As a direct result, we have implemented industry leading field service management software that will help us become more efficient as a business and increase the

level of support to both our customers and field service team. To further support the service team, we have consolidated our spare parts facility into one central location to service a wider range of equipment. We've also ordered 47 service vans, which look great in the new Translift livery." "Perhaps the most pleasing investment is the one we are making in our people," continued Paul. "We have made a number of key appointments by both internal promotions, and recruitment of senior management positions. We have also implemented a number of training and development incentives together with a complete refurbishment of the offices and staff facilities."

Translift has always proudly proclaimed that there is a Bendi to suit almost all applications and budgets, and that hasn't changed. In fact, today with the Landoll partnership, Translift is able to offer customers over 15 different models within the product portfolio of narrow aisle, space saving forklifts; with all at the forefront of build quality, performance and reliability.

To compliment the extensive range of articulated and narrow aisle forklifts, and to give the customers what they have asked for, Translift has recently introduced a range of warehousing products including pallet trucks, stackers and order pickers. ■

**Visit Translift at IMHX**  
**Located: Hall 19, Stand K100**

Translift are delighted to be once again exhibiting at the industry's leading event – IMHX at the NEC in Birmingham. With products ranging from the award winning Mini Bendi pedestrian articulated truck through to the High Lift models, there will be plenty to keep the visitors to its stand interested. Also expected to receive considerable interest is one of the new products for the market – the ECO Bendi. This is a Bendi articulated forklift with full AC technology and brand-new parts throughout, but built within a recycled chassis, which, due to the design of the Bendi are heavier and more robust chassis than traditional forklifts. This high-quality chassis is then stripped, tested and reused saving hours of labour and steel, resulting in significant cost savings for the end user without compromising on performance.

On hand to give expert advice at IMHX will be, according to Paul, one of the industries longest serving and most experienced sales teams. "Translift has always adopted more of a consultative approach to a customers' needs and it has never been about simply selling a fork lift truck. With nearly 100 years of collective experience in a relatively small sales team, we are ideally positioned to create the optimum solution. We offer advice on building design, racking solutions, efficient throughput of goods, etc. We also work with racking partners and designers as needed, but when it comes to understanding the customers' needs it is ultimately our senior people which make the difference. Come and visit us on Stand 19K100 and see how we can save you Space, Time and Money."





# Flexible finance solutions for the materials handling industry

Are you looking to purchase new or used machinery and equipment, or release capital held in existing assets?

Our team of industry experts work closely with businesses, understanding their needs and providing tailor-made solutions for business growth.

We are exhibiting at IMHX 2019

Visit us at stand 20E21

**IMHX**<sup>TM</sup> 2019  
The UK's largest logistics event  
24 - 27 September | NEC • Birmingham

📞 01244 457 569

🌐 [www.closeasset.co.uk/materials-handling](http://www.closeasset.co.uk/materials-handling)

 **Close Brothers**  
Asset Finance

**Modern Merchant Banking**

Close Brothers Asset Finance is a trading style of Close Brothers Limited. Close Brothers Limited is registered in England and Wales (Company Number 00195626) and its registered office is 10 Crown Place, London, EC2A 4FT.

Sponsored by



Corporate & Investment Banking

# IMHX<sup>TM</sup> 2019

The UK's largest logistics event  
24 - 27 September | NEC • Birmingham

# Don't delay!

## Register now for IMHX 2019

Organised by



- **Visit** the largest logistics event in the UK
- **Attend** hundreds of product launches and live demonstrations
- **Gain insight** from free-to-attend seminars
- **Network** with thousands of logistics and supply chain professionals

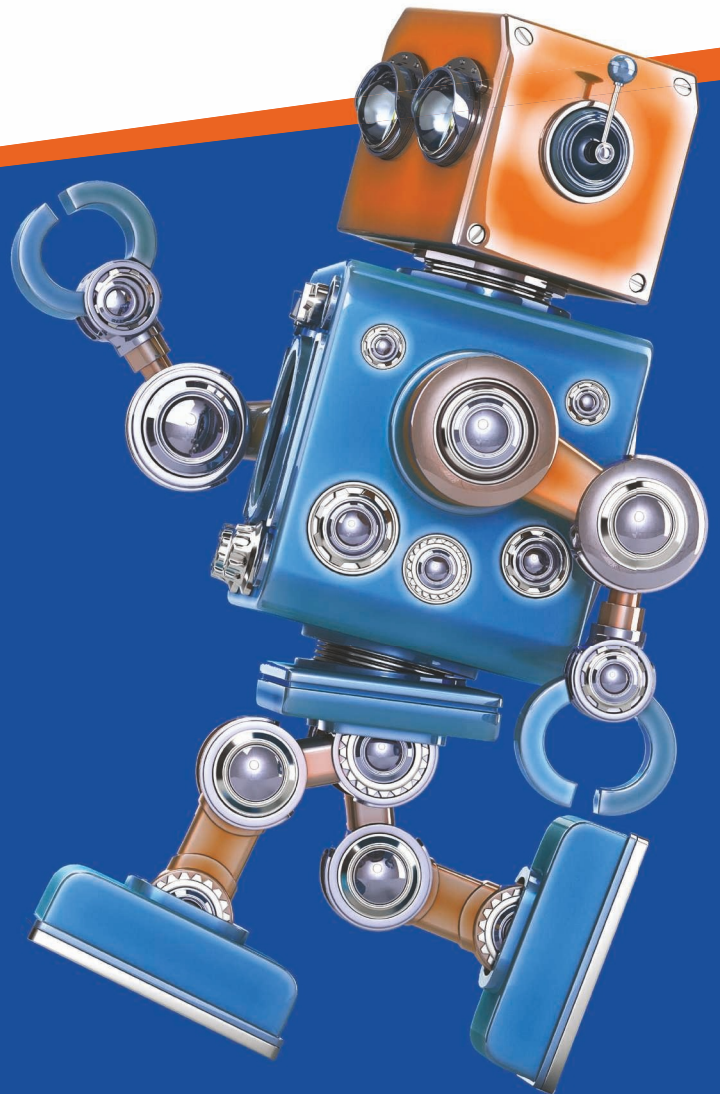

Register for your free pass at

[www.imhx.net](http://www.imhx.net)





# LOOK AT MATERIALS HANDLING FROM A DIFFERENT PERSPECTIVE

An **award winning** range of engine and electric counterbalance forklifts from 1.0 - 25 tonne capacities, reach trucks and warehouse equipment

THINK DIFFERENTLY

THINK DOOSAN



**IMHX<sup>TM</sup> 2019**  
The UK's largest intralogistics event  
24 - 27 September | NEC • Birmingham



**STAND 19G80**

[www.imhx.net](http://www.imhx.net)

GET IN TOUCH:

[DOOSANFLT.COM/01604 825600](http://DOOSANFLT.COM/01604_825600)